

Vespa would like to thank you

for choosing one of its products. We have prepared this manual to help you to get the very best from your vehicle. Please read it carefully before riding the vehicle for the first time. It contains information, tips and precautions for using your vehicle. It also describes features, details and devices to assure you that you have made the right choice. We believe that if you follow our suggestions, you will soon get to know your new vehicle and it will serve you well for a long time to come. This booklet forms an integral part of the vehicle; should the vehicle be sold, it must be transferred to the new owner.

Vespa S 125 ie e 150 ie



The instructions given in this booklet are intended to provide a clear, simple guide to using your scooter; this booklet also details routine maintenance procedures and regular checks that should be carried out on the vehicle at an **authorised Dealer or Service Centres**. The booklet also contains instructions for simple repairs. Any operations not specifically described in this booklet require the use of special tools and/or particular technical knowledge: to carry out these operations, refer to any **authorised Dealer or Service Centres**.



Personal safety

Failure to completely observe these instructions will result in serious risk of personal injury.



Safeguarding the environment

Sections marked with this symbol indicate the correct use of the vehicle to prevent damaging the environment.



Vehicle intactness

The incomplete or non-observance of these regulations leads to the risk of serious damage to the vehicle and sometimes even the invalidity of the guarantee.

The signs that you see on this page are very important. They are used to highlight parts of the booklet that should be read with particular care. The different symbols are used to make each topic in the manual simple and quick to locate.

INDEX

VEHICLE	7	Engine oil level check.....	34
Dashboard.....	9	Engine oil top-up.....	35
Analogue instrument panel.....	10	Engine oil change.....	35
Clock.....	11	Hub oil level.....	37
Key switch.....	12	Tyres.....	39
Locking the steering wheel.....	13	Spark plug dismantlement.....	40
Releasing the steering wheel.....	13	Removing the air filter.....	41
Switch direction indicators.....	14	Air filter cleaning.....	42
Horn button.....	14	Checking the brake oil level.....	43
Light switch.....	15	Braking system fluid top up.....	43
Start-up button.....	15	Battery.....	44
Fuel tank.....	16	Use of a new battery.....	46
Opening the saddle.....	16	Long periods of inactivity.....	46
Keys.....	17	Fuses.....	48
Identification.....	17	Front light group.....	52
Bag clip.....	18	Headlight adjustment.....	54
Helmet Anti-theft Device.....	19	Front direction indicators.....	55
USE	21	Rear optical unit.....	55
Checks.....	22	Rear turn indicators.....	56
Refuelling.....	22	Number plate light.....	57
Tyre pressure.....	23	Rear-view mirrors.....	57
Shock absorbers adjustment.....	24	Front disc brake.....	58
Running in.....	25	Rear drum brake.....	59
Starting up the engine.....	26	Puncture.....	59
Difficult start up.....	27	Periods of inactivity.....	60
Stopping the engine.....	28	Cleaning the vehicle.....	61
Anti-theft ring.....	28	Troubleshooting.....	62
Catalytic silencer.....	29	TECHNICAL DATA	65
Stand.....	29	Kit equipment.....	71
Automatic transmission.....	30	SPARE PARTS AND ACCESSORIES	73
Safe driving.....	30	Warnings.....	74
MAINTENANCE	33	PROGRAMMED MAINTENANCE	75
Engine oil level.....	34	Scheduled maintenance table.....	76

Vespa S 125 ie e 150 ie

Vespa®



**Chap. 01
Vehicle**

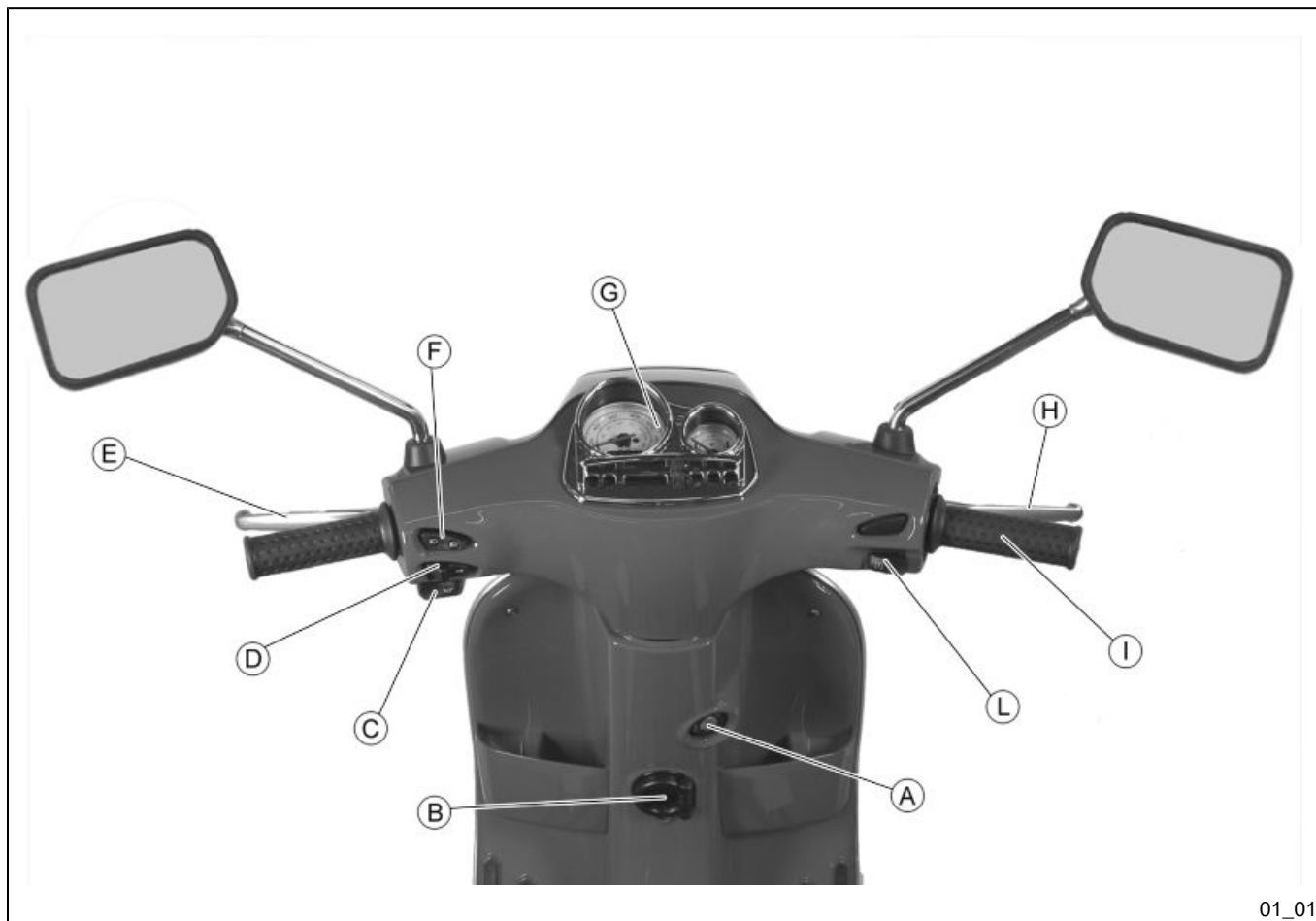

Dashboard (01_01)

A = Ignition key-switch

B = Bag hook

C = Horn button

D = Turn indicator switch

E = Rear brake control lever

F = Headlight switch

G = Analogue instrument panel

H = Front brake control lever

I = Throttle grip

L = Starter button

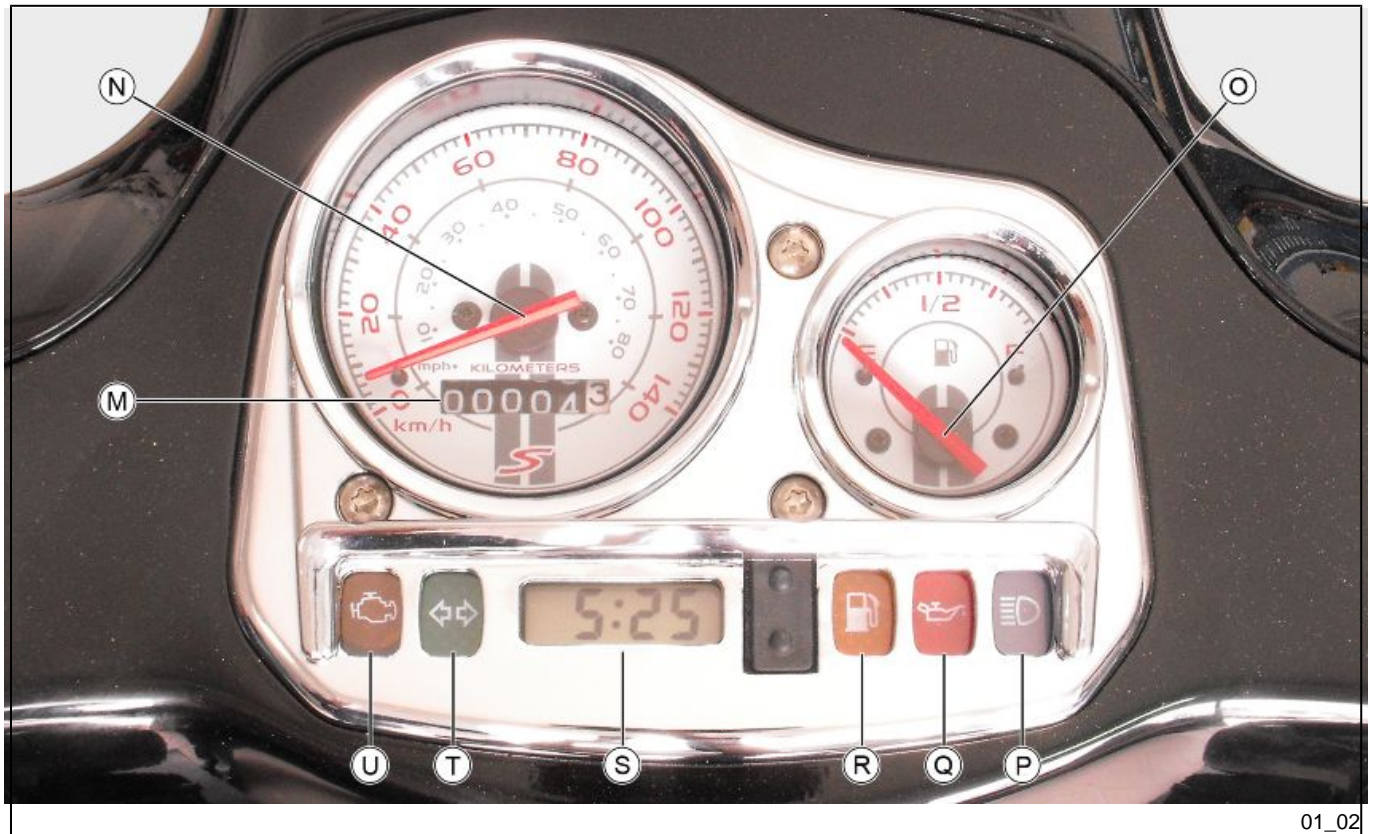

01_02

Analogue instrument panel (01_02)

M= Odometer

N= Speedometer

O = Fuel gauge

P = High-beam warning light

Q = Low oil pressure warning light

R = Fuel gauge warning light

S = Digital clock

T = Turn indicator warning light

U= Engine control telltale light

Clock (01_03)

Located in the instrument panel, it displays hours and minutes with 1 to 12-hour time, AM or PM.

Operate the function selection button «**B**» and month, day and seconds are also displayed besides hours and minutes.

To adjust the different functions, select the desired function with button «**A**» and adjust with button «**B**». The time counter can be reset by pressing button «**A**» with the clock in the seconds function.

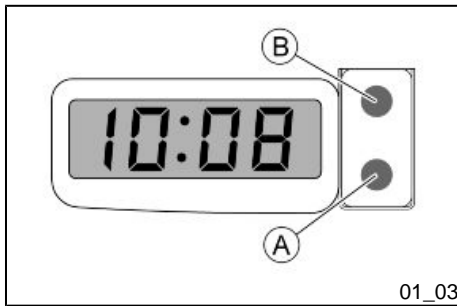

The digital clock is powered by a battery (battery life is about 2 years); lift the whole instrument panel to replace the battery. It is advisable to take your vehicle to an **Authorised Service Centre** for this operation.

WARNING



DEAD BATTERIES ARE HARMFUL TO THE ENVIRONMENT. THEY MUST DISPOSED OF IN SUITABLE CONTAINERS AS PRESCRIBED BY THE REGULATIONS IN FORCE.

Key switch (01_04)

The key switch «A» is located on the knee-guard panel.

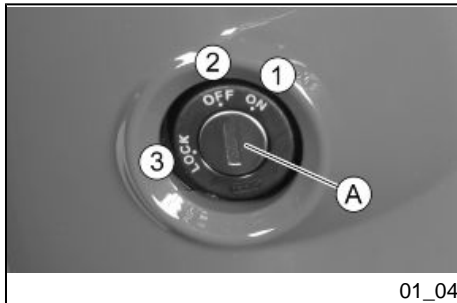

SWITCH POSITIONS

ON «1»: Ready to start position, non-extractable key, mechanical antitheft device disabled.

OFF «2»: Ignition disabled, extractable key, mechanical antitheft device disabled.

LOCK «3»: Ignition disabled, extractable key, mechanical antitheft device enabled.

Locking the steering wheel (01_05)

Turn the handlebar to the left (as far as it will go), turn the key to «**LOCK**» and remove the key.

CAUTION



DO NOT TURN THE KEY TO «LOCK» OR «KEY OFF» WHILE RIDING.

01_05

Releasing the steering wheel (01_06)

Reinsert the key and turn it to «**OFF**».

CAUTION



DO NOT TURN THE KEY TO «LOCK» OR «KEY OFF» WHILE RIDING.

01_06

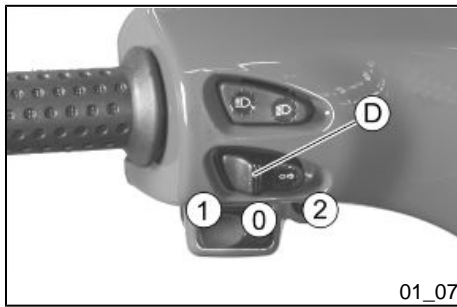

Switch direction indicators (01_07)

Lever «D» towards «1» = left turn indicators switched on;

Lever «D» towards «2» = right turn indicators switched on;

The lever «D» automatically goes back to «0» and the turn indicators remain on; push the lever «D» to turn them off.

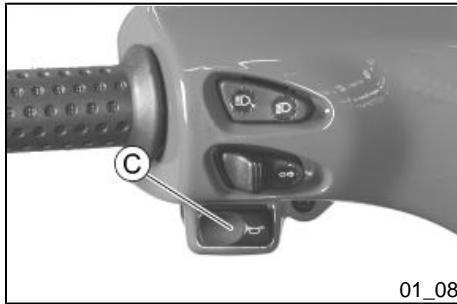

Horn button (01_08)

Push the «C» button to sound the horn.

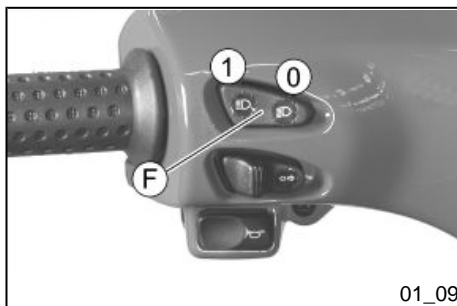

Light switch (01_09)

When the light switch «F» is set to «0», the low-beam light is on. When set to «1», the high-beam light is activated.

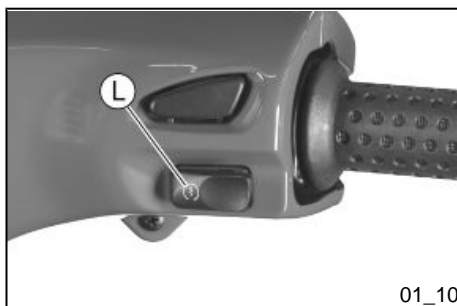

Start-up button (01_10)

To start the engine, pull either of the two brake levers and then push the button «L».

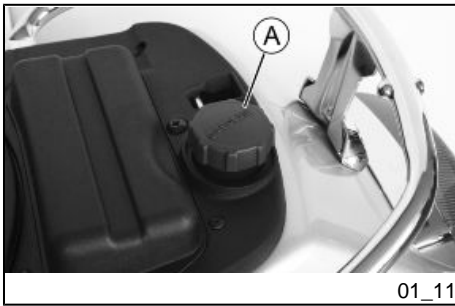

Fuel tank (01_11)

The fuel tank cap «A» is under the saddle. To reach it, tip the saddle forwards.

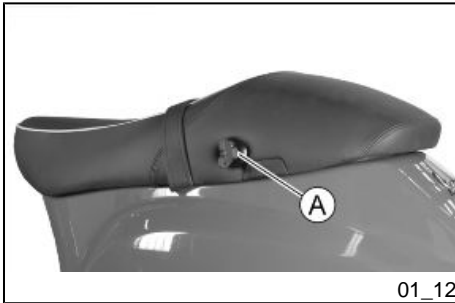

Opening the saddle (01_12)

Insert the key into the saddle lock «A», turn it anticlockwise and tip the saddle forward.

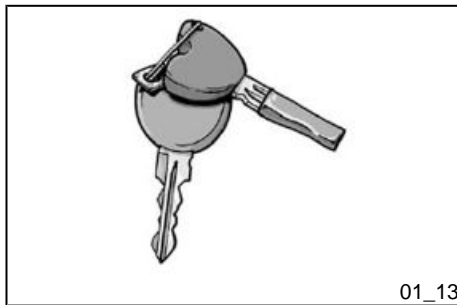

Keys (01_13)

The vehicle is supplied with two keys (one spare) which serve to start the engine and unlock the saddle compartment. The keys are accompanied by a tag marked with the identification code to be quoted when ordering duplicates.

WARNING

WE RECOMMEND KEEPING THE DUPLICATE KEY TOGETHER WITH ITS CODE IN A SAFE PLACE AND NOT ON THE VEHICLE

Identification (01_14, 01_15)

Identification registration numbers are made up of a prefix and a number, stamped on the chassis and on the engine. These numbers must always be quoted when ordering spare parts. We recommend checking that the chassis registration number stamped on the vehicle corresponds with that on the vehicle documentation.

CAUTION



BE REMINDED THAT ALTERING IDENTIFICATION REGISTRATION NUMBERS CAN LEAD TO SERIOUS PENAL SANCTIONS (IMPOUNDING OF THE VEHICLE, ETC.).



01_14

Chassis number

The number «A» is stamped near the battery compartment. Remove the helmet compartment to read it.



01_15

Engine number

The engine number «B» is stamped near the rear left shock absorber lower support.

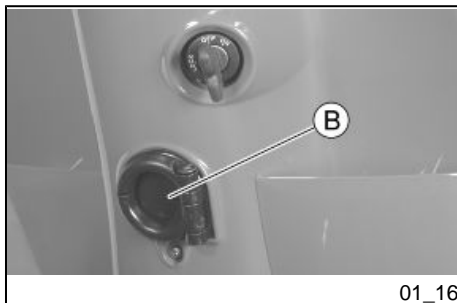

01_16

Bag clip (01_16)

To use the retractable bag hook «B» mounted on the leg shield back plate, pull it slightly towards the back of the vehicle.



Helmet Anti-theft Device (01_17)

Access the antitheft device where a helmet can be hooked by tipping the saddle.

CAUTION



IN ORDER TO AVOID ENDANGERING THE STABILITY WHEN RIDING, DO NOT RIDE THE SCOOTER WITH THE HELMET INSERTED INTO THE ANTITHEFT DEVICE.

WARNING



THIS ACCESSORY IS NOT A THEFT PREVENTION GUARANTEE, IT IS ONLY A DETERRENT.

Vespa S 125 ie e 150 ie

Vespa®



Chap. 02
Use

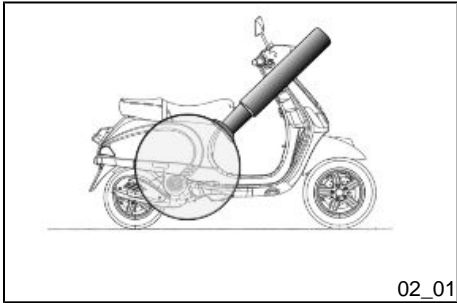

Checks (02_01)

Before using the vehicle, check:

1. that the fuel tank is full.
2. Rear hub oil level.
3. Engine oil level (see the «Engine oil level» section).
4. That the tyres are properly inflated.
5. The correct functioning of headlights, rear light and turn indicators.
6. The correct functioning of front and rear brakes.

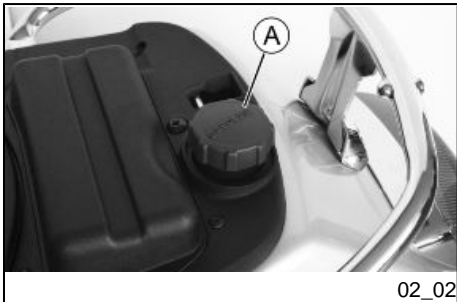

Refuelling (02_02)

Fill fuel tank «A» with unleaded petrol (minimum octane rating = 95).

When the fuel reaches the low fuel level, the warning light on the instrument panel lights up.

CAUTION



SHUT OFF THE ENGINE BEFORE REFUELLING WITH PETROL. PETROL IS HIGHLY FLAMMABLE. DO NOT LET PETROL SPILL FROM THE TANK OR WHILE REFUELLING

CAUTION

DO NOT BRING NAKED FLAMES OR CIGARETTES NEAR THE MOUTH OF THE FUEL TANK: FIRE HAZARD. ALSO AVOID INHALING HARMFUL VAPOURS.

FUEL TANK CAPACITY

Fuel tank (reserve)	~8.3 ± 0.5 l (~2.5 l)
---------------------	-----------------------

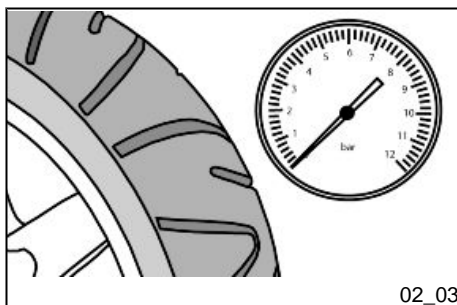
**Tyre pressure (02_03)**

Check tyre pressure as indicated in the scheduled maintenance table.

CAUTION

TYRE PRESSURE SHOULD BE CHECKED WHEN TYRES ARE COLD. INCORRECT TYRE PRESSURE CAUSES ABNORMAL TYRE WEAR AND MAKES RIDING DANGEROUS.

TYRES MUST BE REPLACED WHEN THE TREAD REACHES THE WEAR LIMITS SET FORTH BY LAW.

TYRE INFLATION PRESSURE

Front tyre pressure (with passenger)	1.6 bar (1.6 bar)
Rear tyre pressure (with passenger)	2.0 bar (2.3 bar)

TYRES

Front tyre	Tubeless, 110/70 - 11" 45L
Rear tyre	Tubeless, 120/70 - 10" 54L

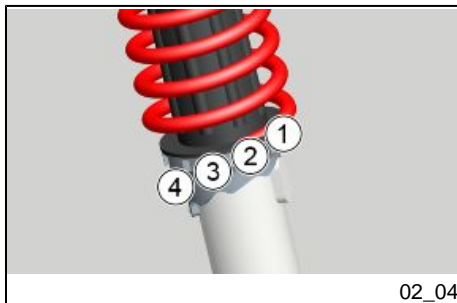

Shock absorbers adjustment (02_04, 02_05)

The preloading of the spring can be adjusted to 4 positions using the ring nut located in the lower part of the shock absorbers and the specific spanner supplied.

Position 1: minimum preload: rider only

Position 2: medium preloading: rider only

Position 3: medium preloading: rider and passenger

Position 4: maximum preloading: rider, passenger, and luggage.

In order to carry out this operation you will need to use the specific spanner in the kit. Spring preloading increases by turning the ring nut towards «**A**», but decreases if the ring nut is turned towards «**B**».

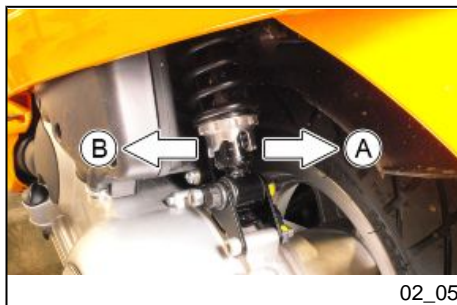

02_05

CAUTION

RIDING THE VEHICLE WITH THE SPRING PRELOADING NOT CORRECTLY SET FOR THE RIDER AND POSSIBLE PASSENGER, COULD REDUCE THE COMFORT OF THE RIDE AND THE PRECISION OF THE STEERING.

WARNING

WE RECOMMEND WEARING GLOVES WHILE CARRYING OUT THIS OPERATION IN ORDER TO AVOID INJURIES.

Running in (02_06)**WARNING**

DURING THE FIRST 1000 KM DO NOT RIDE THE VEHICLE OVER 80% OF ITS MAXIMUM SPEED. AVOID TWISTING THE THROTTLE GRIP FULLY OR KEEPING A CONSTANT SPEED ALONG LONG SECTIONS OF ROAD. AFTER THE FIRST 1000 KM, GRADUALLY INCREASE SPEED UNTIL REACHING THE MAXIMUM PERFORMANCE.

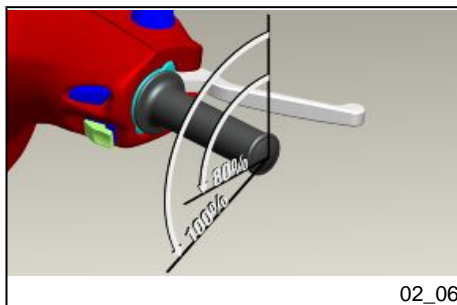

02_06

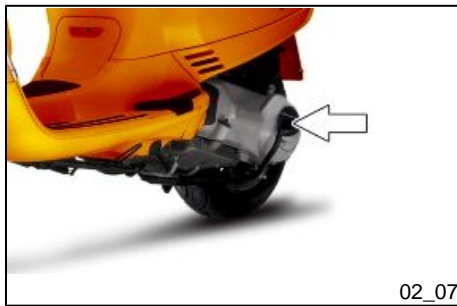

02_07



02_08



02_09

Starting up the engine (02_07, 02_08, 02_09, 02_10, 02_11)

The vehicle is equipped with automatic transmission with direct drive, so that starting is effected by turning the throttle grip to idle speed; to start-off from a stationary position, progressively twist the throttle grip. The vehicle is equipped with an electrical fuel pump that switches on automatically as soon as the engine is started.

To start it up, it is necessary to:

- Rest the vehicle on its centre stand, ensuring the rear wheel is not touching the ground.
- Keep the throttle grip to idle speed.
- Insert the key into the key switch and turn it to « ON ».
- Wait for the engine control telltale light to turn off.
- Push the starter button « A » after pulling the front brake lever « B » or the rear brake lever « C ».

CAUTION



DO NOT CARRY OUT THESE OPERATIONS IN CLOSED AREAS SINCE EXHAUST GASES ARE TOXIC.

CAUTION



DUE TO THE HIGH TEMPERATURES THE CATALYTIC CONVERTER CAN REACH, ALWAYS TAKE CARE, WHEN PARKING THE VEHICLE, THAT THE SILENCER DOES NOT COME INTO CONTACT WITH FLAMMABLE MATERIALS, TO AVOID SERIOUS BURNS.

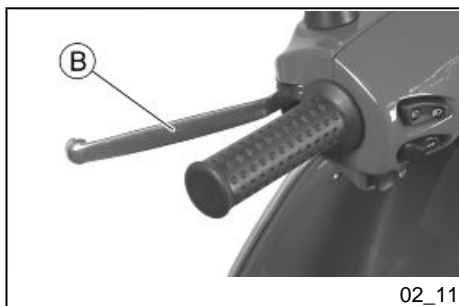
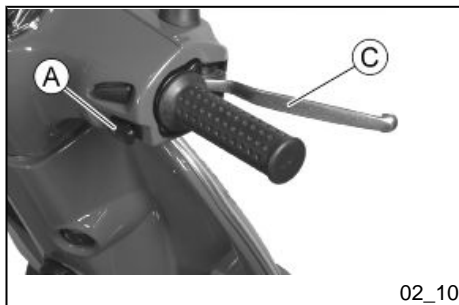

Difficult start up (02_12)

In the rare case of a flooded engine, and in order to facilitate start-up, try putting the vehicle into motion with the throttle slightly open. It is however necessary, once the engine is started, to take your vehicle to an **Authorised Service Centre** to determine the cause of this problem and to re-establish the vehicle proper functioning.

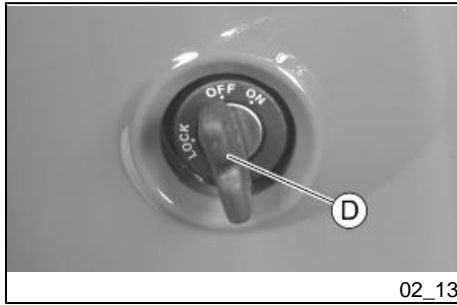

Stopping the engine (02_13)

Stop acceleration, then turn the key switch «D» to «OFF » to stop the engine (extractable key).

CAUTION



DUE TO THE HIGH TEMPERATURES THE CATALYTIC CONVERTER CAN REACH, ALWAYS TAKE CARE, WHEN PARKING THE VEHICLE, THAT THE SILENCER DOES NOT COME INTO CONTACT WITH FLAMMABLE MATERIALS, TO AVOID SERIOUS BURNS.



Anti-theft ring (02_14)

The ring shown in the figure, located on the right side of the vehicle is used to fasten the vehicle to a stable object using a vehicle chain. Do not use the ring for other purposes.

WARNING



THIS ACCESSORY IS NOT A THEFT PREVENTION GUARANTEE, IT IS ONLY A DETERRENT.

Catalytic silencer (02_15)

CAUTION



TAMPERING WITH THE CATALYTIC SILENCER MAY CAUSE SEVERE DAMAGE TO THE ENGINE

CAUTION



WHEN PARKING THE VEHICLE, DUE TO THE HIGH TEMPERATURES THE CATALYTIC CONVERTER CAN REACH, ALWAYS BE CAREFUL THAT THE MUFFLER DOES NOT COME INTO CONTACT WITH FLAMMABLE MATERIALS, TO AVOID SERIOUS BURNS.

Stand (02_16)

Lower the projection of the centre stand by kicking the bracket while pulling the vehicle backward, holding onto the handlebars.



02_15

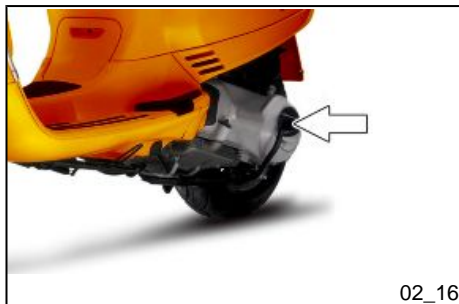

02_16



Automatic transmission (02_17)

To ensure simple, pleasurable riding, the vehicle is equipped with automatic transmission with regulator and centrifugal clutch. The system is designed to give the best possible performance in terms of both acceleration and consumption, on level ground and uphill, thanks to the adjustments made to engine speed and transmitted torque. If you have to stop on an uphill slope (traffic lights, traffic jam, etc.) only use the brake to keep the vehicle still, leaving the motor running at idling speed. Using the motor to keep the vehicle still can cause the clutch to overheat. This problem is due to the friction of the clutch parts on the clutch bell. It is therefore recommended to avoid conditions of prolonged clutch slippage leading to clutch overheating (for example, as well as the situation described above, riding uphill fully laden on steep slopes or starting off on slopes greater than 25%, etc.):

1. Do not continue riding in such conditions.
2. Let the clutch cool down with the motor at idling speed for a few minutes



Safe driving (02_18)

Some simple tips are provided below that will enable you to use your vehicle on a daily basis, confidently and safely. Your skill and your mechanical knowledge are the basis of safe riding. We recommend trying out the vehicle in traffic-free zones to familiarise with it.

1. Before riding off, remember to put the helmet on and fasten it correctly.
2. Reduce speed on rough roads and ride with care.
3. After riding on a long stretch of wet road without using the brakes, braking can be poor at the beginning. In these conditions, it is a good idea to apply the brakes from time to time.
4. Do not brake hard on wet, unsurfaced or slippery roads.
5. Avoid riding off by mounting the scooter when it is resting on its support. In any case, in order to avoid abrupt departures, the rear wheel should not be turning when it comes into contact with the ground.

6. If the vehicle is used on roads covered with sand, mud, snow mixed with salt, etc., clean the brake disc frequently with a mild detergent in order to prevent abrasive particles from building up inside the holes, which can result in early brake pad wear.

CAUTION

ALWAYS RIDE WITHIN YOUR LIMITS RIDING UNDER THE INFLUENCE OF ALCOHOL OR OTHER DRUGS AND CERTAIN MEDICINES IS EXTREMELY DANGEROUS.

CAUTION

ANY ELABORATION THAT MODIFIES THE VEHICLE'S PERFORMANCES, SUCH AS TAMPERING WITH ORIGINAL STRUCTURAL PARTS IS STRICTLY FORBIDDEN BY LAW, AND RENDERS THE VEHICLE NO LONGER CONFORMING TO THE APPROVED TYPE AND DANGEROUS FOR RIDING.

CAUTION

DO NOT ADJUST THE MIRRORS WHILE RIDING. THIS COULD CAUSE YOU TO LOOSE CONTROL OF THE VEHICLE.

WARNING

IN ORDER TO PREVENT ANY ACCIDENTS RIDE VERY CAREFULLY AFTER ADDING ACCESSORIES AND WHILE CARRYING LUGGAGE. THE ADDITION OF ACCESSORIES AND LUGGAGE CAN REDUCE YOUR SCOOTER STABILITY AND PERFORMANCE, AS WELL AS THE LEVEL OF SAFETY DURING USE. (SEE THE «SPARE PARTS AND ACCESSORIES» SECTION)

Vespa S 125 ie e 150 ie

Vespa®



**Chap. 03
Maintenance**

Engine oil level

In 4T engines, the engine oil is used to lubricate the distribution elements, the bench bearings and the thermal group. **An insufficient quantity of oil can cause serious damage to the engine itself.** In all 4T engines the decay of oil characteristics as well as some consumption is normal. Consumption can particularly reflect the conditions of use (i.e. when driving at "full acceleration" all the time, oil consumption increases). **In order to avoid problems, it is advisable to control oil level every time the vehicle is used.**

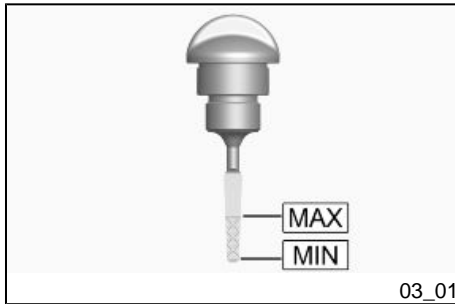

Engine oil level check (03_01, 03_02)

Every time the vehicle is used, visually inspect the level of the engine oil when the engine is cold (after **completely unscrewing** the oil cap/dipstick). The oil level should be somewhere between the MAX and MIN index marks on the level rod; «**A**»; while the oil is being checked, the vehicle must be resting on its centre stand on an even, horizontal surface.

If the check is carried out after the vehicle has been used, and therefore with a hot engine, the level line will be lower; in order to carry out a correct check, wait at least 10 minutes after the engine has been stopped so as to get the correct level.

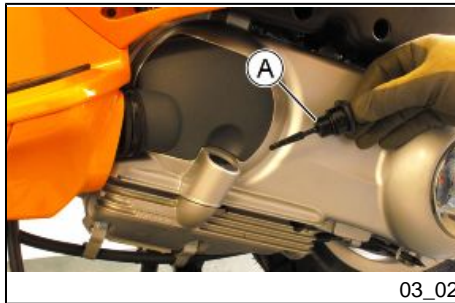

ENGINE OIL CAPACITY:

Engine oil

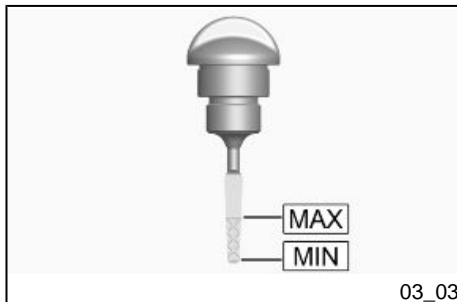
~ 1.100 cm³

03_03

Engine oil top-up (03_03)

Always check oil level before carrying out top-ups and add oil **without exceeding the MAX level**. An engine oil check-up and top-up should be carried out as indicated in the scheduled maintenance table at an **Authorised Service Centre**.

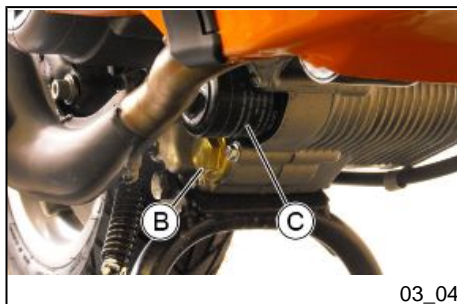

03_04

Engine oil change (03_04, 03_05, 03_06)

The oil and the cartridge filter «C» must be changed as indicated in the scheduled maintenance tables at an **Authorised Service Centre**. The engine should be emptied by draining the oil from the drainage plug «B» of the gauze filter on the flywheel side. In order to facilitate oil drainage, loosen the cap/dipstick. Since a certain quantity of oil still remains in the circuit, refill with approx. 850 ÷ 900 cm³ of oil through the cap «A». Then start up the vehicle, leave it running for a few minutes and switch it off: after 5 minutes, check the level and if necessary, top-up **without exceeding the MAX level**. The cartridge filter must be replaced at every oil change. For top-ups and changes, use new oil of the recommended type.

WARNING

RUNNING THE ENGINE WITH INSUFFICIENT LUBRICATION OR WITH INADEQUATE LUBRICANTS ACCELERATES THE WEAR AND TEAR OF THE MOVING PARTS AND CAN CAUSE IRRETRIEVABLE DAMAGE.

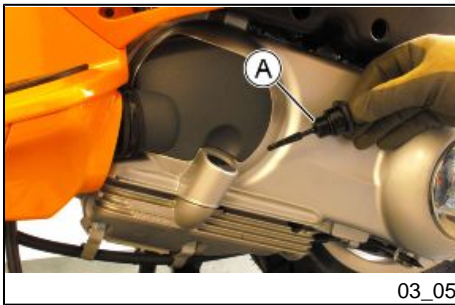

03_05

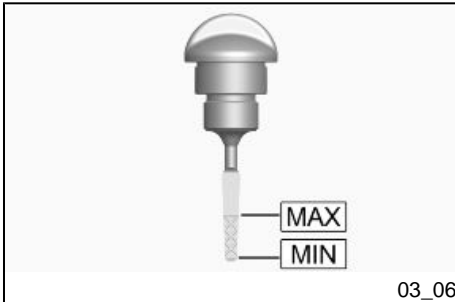

03_06

WARNING

EXCESSIVE OIL LEVEL AT TOP-UPS CAN LEAD TO SCALE FORMATION AND VEHICLE MALFUNCTION.

CAUTION

USED OILS CONTAIN SUBSTANCES HARMFUL TO THE ENVIRONMENT. FOR OIL CHANGE, CONTACT AN AUTHORISED SERVICE CENTRE WHICH IS EQUIPPED TO DISPOSE OF USED OILS IN AN ENVIRONMENTALLY FRIENDLY AND LEGAL WAY.

CAUTION

USING OILS OTHER THAN THOSE RECOMMENDED CAN SHORTEN THE LIFE OF THE ENGINE.

Recommended products

AGIP CITY HI TEC 4T

Engine oil

SAE 5W-40, API SL, ACEA A3, JASO MA Synthetic oil

ENGINE OIL CAPACITY:

Engine oil	~ 1.100 cm ³
------------	-------------------------

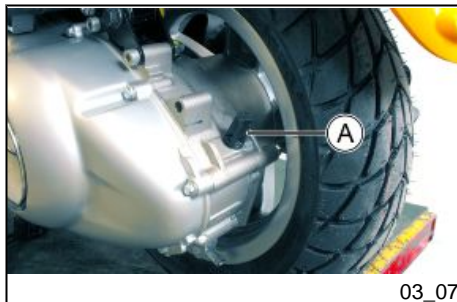

03_07

Hub oil level (03_07, 03_08, 03_09)

Make sure there is oil in the rear hub checking this at the intervals specified in the scheduled maintenance table.

To check the rear hub oil level, proceed as follows:

- Park the vehicle on level ground and rest it on its centre stand.
- Unscrew the oil dipstick «A» and dry it with a clean cloth. Reinsert it by screwing it in completely.
- Pull out the dipstick and check that the oil level is between the **MIN** and **MAX** reference marks. If the oil level is below the **MIN** notch, refill the hub with the right amount of oil.
- Screw up the oil dipstick back in and make sure it is locked properly in place.

N.B.

THE REFERENCE MARKS ON THE HUB OIL LEVEL DIPSTICK, EXCEPT FOR THE ONE INDICATING THE "MAX" LEVEL, REFER TO OTHER MODELS BY THE MANUFACTURER AND HAVE NO SPECIFIC FUNCTION FOR THIS MODEL.

CAUTION



RIDING THE VEHICLE WITH INSUFFICIENT HUB LUBRICATION OR WITH CONTAMINATED OR IMPROPER LUBRICANTS ACCELERATES THE WEAR AND TEAR OF THE MOVING PARTS AND CAN CAUSE SERIOUS DAMAGE.

CAUTION



USED OILS CONTAIN SUBSTANCES HARMFUL TO THE ENVIRONMENT. FOR OIL CHANGE, CONTACT AN AUTHORISED SERVICE CENTRE WHICH IS EQUIPPED TO DISPOSE OF USED OILS IN AN ENVIRONMENTALLY FRIENDLY AND LEGAL WAY.

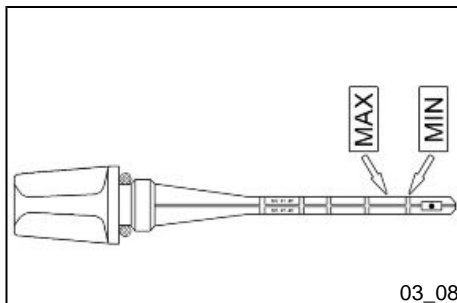

03_08

Recommended products

AGIP ROTRA 80W-90

Rear hub oil

SAE 80W/90 Oil that exceeds the requirements of API GL3 specifications

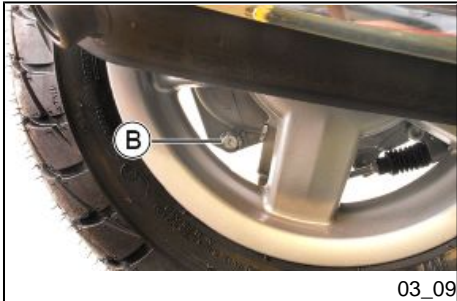

REPLACEMENT

- 1) Remove the oil dipstick.
- 2) Unscrew the oil drainage screw «**B**» and drain out all the oil.
- 3) Screw back the drainage screw and refill the hub using the recommended oil quantity and type.

HUB OIL CAPACITY

Hub oil

~ 100 cm³

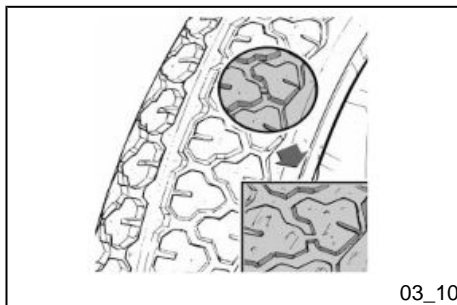

03_10

Tyres (03_10)

Periodically check the inflation pressure of each tyre (when cold).

Tyres are fitted with wear indicators; tyres should be replaced as soon as these indicators become visible on the tyre tread. Also check that the tyres do not show signs of splitting at the sidewalls or irregular tread wear; If this occurs, go to an authorised workshop or at least a workshop adequately equipped to remove and refit tyres.

CAUTION



TYRE PRESSURE SHOULD BE CHECKED WHEN TYRES ARE COLD. INCORRECT TYRE PRESSURE CAUSES ABNORMAL TYRE WEAR AND MAKES RIDING DANGEROUS.

TYRES MUST BE REPLACED WHEN THE TREAD REACHES THE WEAR LIMITS SET FORTH BY LAW.

TYRES

Front tyre	Tubeless, 110/70 - 11" 45L
Rear tyre	Tubeless, 120/70 - 10" 54L

TYRE INFLATION PRESSURE

Front tyre pressure (with passenger)	1.6 bar (1.6 bar)
Rear tyre pressure (with passenger)	2.0 bar (2.3 bar)

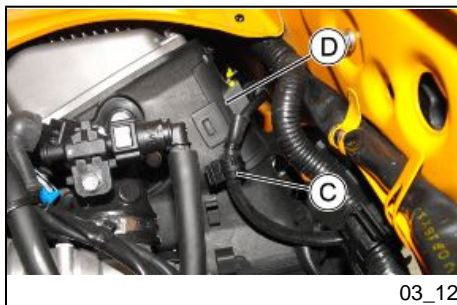
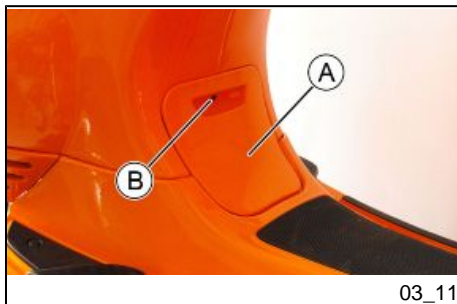

Spark plug dismantlement (03_11, 03_12, 03_13)

In order to inspect the spark plug, follow the operation described when the engine is cold:

- Lift the saddle and remove the helmet compartment. Remove the spark plug inspection cover «A» by unscrewing the screw «B».
- From the engine compartment, release clamp «C», pull cover «D» upwards and slide off the spark plug shielded cap.
- Remove the spark plug using the box-spanner supplied.

Use the box-spanner to refit the spark plug in its seat, then tighten it. Care should be taken while installing and fixing it with the correct inclination. Before refitting the shielded cap, insert it first in the cover. Tie down the cable in the corresponding clamp.

Be extremely careful when carrying out the operations described above, insert your left hand on the spark plug inspection door side and your right hand from the helmet compartment side.

CAUTION



FOLLOW THESE PROCEDURES VERY CAREFULLY TO AVOID ANY SEVERE DAMAGE THAT MAY BE CAUSED BY THE VERY POWERFUL IGNITION SYSTEM.

CAUTION



THE SPARK PLUG MUST BE REMOVED WHEN THE ENGINE IS COLD. USING IGNITION ELECTRONIC CENTRAL UNITS OR SPARK PLUGS OTHER THAN THE TYPES PRESCRIBED (SEE «TECHNICAL DATA» SECTION) CAN CAUSE SERIOUS DAMAGE TO THE ENGINE.

CAUTION

PERFORM THE OPERATIONS CAREFULLY.

DO NOT DAMAGE THE TONGUES OR THEIR SEATS. HANDLE THE PAINTED AND PLASTIC COMPONENTS CAREFULLY. DO NOT SCRATCH OR DAMAGE THEM.

RECOMMENDED SPARK PLUG

Spark plug (125cc)	NGK CR8EB
Spark plug (150cc)	NGK CR7EB
Electrode gap	0.7 to 0.8 mm

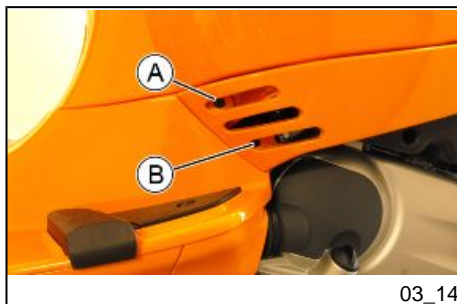

03_14

Removing the air filter (03_14, 03_15)

Remove the side fairing by undoing the screw «A» and the smaller screw «B». Take off air cleaner cover «D» after having unscrewed the 6 fixing screws «C», then take out the filter.

CAUTION

IN CASE OF RIDING ON DUSTY ROADS IT IS ADVISABLE TO CLEAN THE AIR FILTER MORE FREQUENTLY THAN INDICATED IN THE RELEVANT CHAPTER ON SCHEDULED MAINTENANCE.

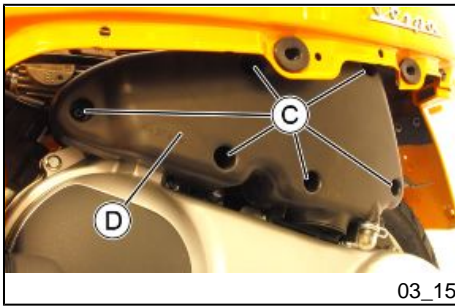

03_15

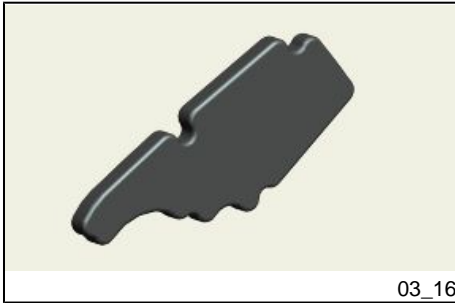

03_16

Air filter cleaning (03_16)

1. Wash the sponge with water and mild soap.
2. Dry it with a clean cloth and short blasts of compressed air.
3. Impregnate the sponge with a mixture of 50% petrol and 50% specified oil.
4. Gently squeeze the filtering element, let it drip dry and then refit it.

CAUTION



IF THE VEHICLE IS USED ON DUSTY ROADS, IT IS NECESSARY TO SERVICE THE AIR FILTER MORE OFTEN TO AVOID DAMAGING THE ENGINE.

Recommended products

AGIP FILTER OIL

Oil for air filter sponge

Mineral oil with specific additives for increased adhesiveness

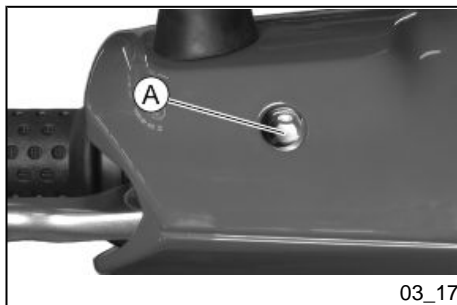

03_17

Checking the brake oil level (03_17)

The brake fluid reservoir is equipped with a sight glass «A» made of transparent material; the quantity of liquid contained in the sight glass indicates the level of liquid in the reservoir.

When the sight glass «A» is full, the level inside the reservoir exceeds the MIN level; when it is partially full, the level drops to the MIN level; when it is fully empty, the level of fluid in the reservoir is below the MIN level.

The brake fluid level may fall due to wear on the brake pads. In case the pad wear is below the minimum mark, contact an **Authorised Service Centre** to have the braking system thoroughly checked.

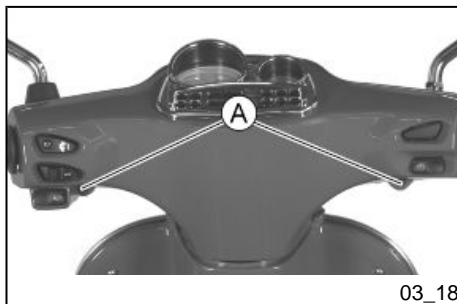

03_18

Braking system fluid top up (03_18, 03_19, 03_20)

Proceed as follows:

1. Remove the rear-view mirrors.
2. Undo the two screws «A».
3. Undo the screw «B» and remove the front handlebar cover.
4. Remove the reservoir cover «C» by loosening the two fixing screws «D» and refill with the prescribed brake fluid type only and without exceeding the maximum level.

Under standard climatic conditions, replace fluid as indicated in the scheduled maintenance table. This operation must be carried out by trained technicians; take your scooter to an **authorised Service Centre or Dealer**.

WARNING



ONLY USE DOT 4 CLASS BRAKE FLUIDS. BRAKING CIRCUIT FLUIDS ARE HIGHLY CORROSIVE. MAKE SURE THAT IT DOES NOT COME INTO CONTACT WITH THE PAINTWORK

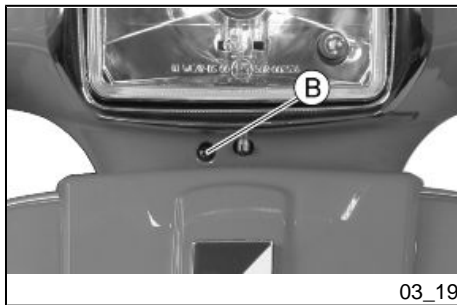

03_19

CAUTION

AVOID CONTACT OF BRAKE FLUID WITH EYES, SKIN, AND CLOTHING. IN CASE OF CONTACT, RINSE WITH WATER. THE BRAKING CIRCUIT FLUID IS HYGROSCOPIC, THAT IS, IT ABSORBS HUMIDITY FROM THE SURROUNDING AIR. IF THE HUMIDITY IN THE BRAKING FLUID EXCEEDS A CERTAIN VALUE, IT WILL LEAD TO INEFFICIENT BRAKING. NEVER USE BRAKING FLUID KEPT IN CONTAINERS THAT HAVE ALREADY BEEN OPENED, OR PARTIALLY USED.

Recommended products**AGIP BRAKE 4**

Brake fluid

FMVSS DOT 4 Synthetic fluid

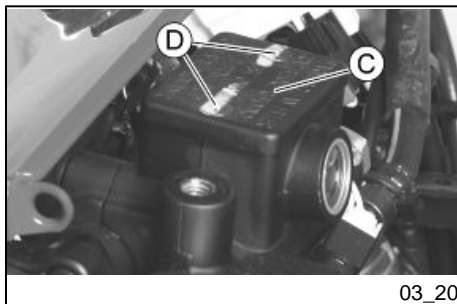

03_20

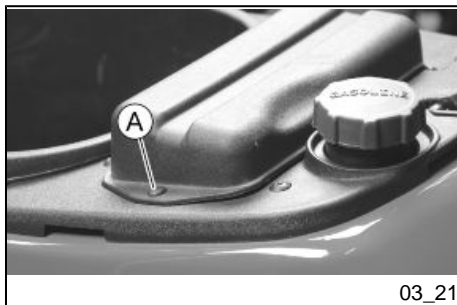

03_21

Battery (03_21)

To access the battery, tilt the saddle forwards, then remove the battery compartment access door by unscrewing the star-shaped screw "A" shown in the figure.

The battery is the electrical device that requires the most frequent attention and the most thorough maintenance.

WARNING

USED BATTERIES ARE HARMFUL FOR THE ENVIRONMENT. COLLECTION AND DISPOSAL SHOULD BE CARRIED OUT IN COMPLIANCE WITH REGULATIONS IN FORCE.

CAUTION

ELECTROLYTE CONTAINS SULPHURIC ACID: AVOID CONTACT WITH EYES, SKIN AND CLOTHES. IN CASE OF ACCIDENTAL CONTACT, RINSE WITH ABUNDANT WATER AND CONSULT A DOCTOR.

CAUTION

IN ORDER TO AVOID DAMAGING THE ELECTRIC SYSTEM, NEVER DISCONNECT THE WIRING WHILE THE ENGINE IS RUNNING. DO NOT TIP THE VEHICLE TOO MUCH IN ORDER TO AVOID DANGEROUS LEAKAGE OF THE BATTERY ELECTROLYTE



Use of a new battery (03_22)

To install a new battery:

1. Place the battery in its housing.
2. Connect the positive pole «+» first and then the negative pole «-».
3. Fit the battery cover.

CAUTION



DO NOT REVERSE THE POLARITY: RISK OF SHORT CIRCUIT AND DAMAGE TO THE ELECTRICAL SYSTEM.

WARNING



USED BATTERIES ARE HARMFUL FOR THE ENVIRONMENT. COLLECTION AND DISPOSAL SHOULD BE CARRIED OUT IN COMPLIANCE WITH REGULATIONS IN FORCE.

Characteristic

Battery

Sealed, 12 V / 10 Ah

Long periods of inactivity

Battery performance will decrease if the vehicle is not used for a long time. This is the result of the natural phenomenon of battery discharging, and may be due to residual absorption by vehicle components with constant power consumption. Poor battery performance may also be due to environmental conditions and the cleanness of the

poles. In order to avoid difficult starts and/or irreversible damage to the battery, follow any of these steps:

- **At least once a month** start the engine and run it slightly above idle speed for 10-15 minutes. This keeps all the engine components, as well as the battery, in good working order.

- Take your vehicle to a garage (as indicated in the «Vehicle not used for extended periods» section) to have the battery removed. Have the battery cleaned, charged fully and stored in a dry, ventilated place. Recharge **at least once every two months**.

N.B.

THE BATTERY MUST BE CHARGED WITH A CURRENT EQUAL TO 1/10 OF THE RATED CAPACITY OF THE BATTERY AND FOR NOT LONGER THAN 10 HOURS. CONTACT AN AUTHORISED SERVICE CENTRE TO CARRY OUT THIS OPERATION SAFELY. WHEN REFITTING THE BATTERY MAKE SURE THE LEADS ARE CORRECTLY CONNECTED TO THE TERMINALS.

WARNING



DO NOT DISCONNECT THE BATTERY CABLES WITH THE ENGINE RUNNING, THIS CAN CAUSE IRREPARABLE DAMAGE TO THE VEHICLE'S ELECTRONIC CONTROL UNIT.

WARNING



USED BATTERIES ARE HARMFUL FOR THE ENVIRONMENT. COLLECTION AND DISPOSAL SHOULD BE CARRIED OUT IN COMPLIANCE WITH REGULATIONS IN FORCE.



03_23

Fuses (03_23, 03_24, 03_25, 03_26, 03_27)

The electrical system is protected by:

- a 20A and 15A fuse, terminal block «A» located in the battery compartment under the saddle;
- two 10A fuses, terminal block «B» and two 7.5A fuses, terminal block «C» located inside the legshield under the steering cover;

To reach them:

- Using a screwdriver, remove the clip-on badge «D».
- Unscrew the two screws «E» and remove the steering cover.

Before replacing a fuse, find and solve the failure that caused it to blow. Do not replace the fuse with any alternative form of conductor

CAUTION



IN ORDER TO AVOID DAMAGING THE ELECTRIC SYSTEM, NEVER DISCONNECT THE WIRING WHILE THE ENGINE IS RUNNING. DO NOT TIP THE VEHICLE TOO MUCH IN ORDER TO AVOID DANGEROUS LEAKAGE OF THE BATTERY ELECTROLYTE

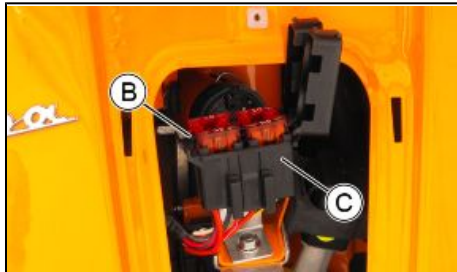

03_24



03_25

CAUTION



MODIFICATIONS OR REPAIRS TO THE ELECTRICAL SYSTEM, PERFORMED INCORRECTLY OR WITHOUT STRICT ATTENTION TO THE TECHNICAL SPECIFICATIONS OF THE SYSTEM CAN CAUSE MALFUNCTIONING AND RISK OF FIRE.

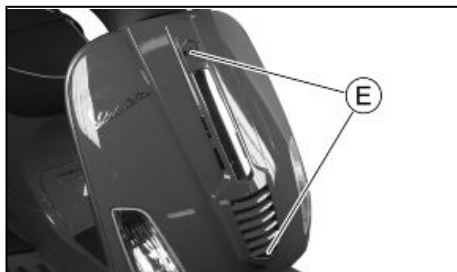

03_26

CAUTION

PERFORM THE OPERATIONS CAREFULLY.

DO NOT DAMAGE THE TONGUES OR THEIR SEATS. HANDLE THE PAINTED AND PLASTIC COMPONENTS CAREFULLY. DO NOT SCRATCH OR DAMAGE THEM.

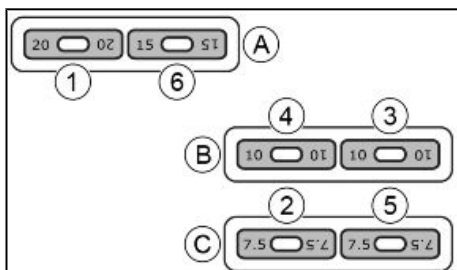

03_27

FUSES

Fuse No. 1

Capacity: 20A

Protected circuits: battery-powered recharge system and fuse No. 4. Live power supply to fuses No. 2, 3 and 5.

Location: battery compartment.

Fuse No. 2

Capacity: 7.5A

Protected circuits: live power supply to injection load solenoid, Immobilizer aerial, ECU.

Location:steering cover.

Fuse No. 3

Capacity: 10 A

Protected circuits: live power supply to instrument panel, horn, turn indicator control device, stop light, start-up remote control switch.

Location:steering cover.

Fuse No. 4

Capacity: 10 A

Protected circuits: battery-powered headlight solenoid, antitheft-device pre-installation.

Location:steering cover.

Fuse No. 5

Capacity: 7.5A

Protected circuits: live power supply to daylight running light, dashboard lighting.

Location:steering cover.

Fuse No. 6

Capacity: 15A

Protected circuits: battery-powered injection solenoid, ECU, Immobilizer LED.

Location: battery compartment.

BULBS

High/low beam light bulb

Type: Halogen (H4)

Power: 12V - 55/60W

Quantity: 1

Front side light bulb

Type: Incandescent (W2.1x9.5d)

Power: 12V - 5W

Quantity: 1

Front turn indicator light bulb

Type: Incandescent (BA 15s)

Power: 12V - 10W

Quantity: 1 RHS + 1 LHS

Rear turn indicator light bulb

Type: Incandescent (BA 15s)

Power: 12V - 10W

Quantity: 1 RHS + 1 LHS

Stop and tail light bulb

Type: Incandescent (BAY 15s)

Power: 12V - 21/5W

Quantity: 1

License plate bulb

Type: Incandescent (W2.1 x 9.5D)

Power: 12V - 5W

Quantity: 1

Instrument panel bulb

Type: Incandescent

Power: 12V - 2W

Quantity: 3

Daylight running light, fuel reserve and engine check warning light bulbs.

Type: Incandescent

Power: 12V - 2W

Quantity: 3

Oil pressure, turn indicator and low-beam light warning light bulbs.

Type: Incandescent

Power: 12V - 1.2W

Quantity: 3

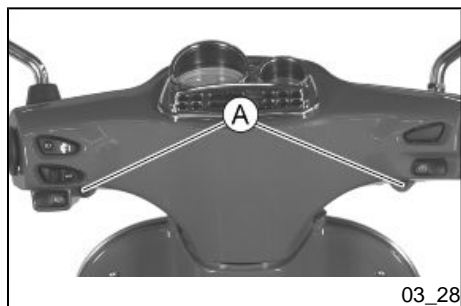

Front light group (03_28, 03_29, 03_30, 03_31)

To access the headlight bulbs, remove the front of the handlebar cover, as follows:

1. Remove the rear-view mirrors.
2. Undo the three screws holding the handlebar cover. The front central screw «B» and the two rear screws «A». Once this is done, the handlebar cover can be removed.

To replace the high-/low-beam headlight bulb:

1. Disconnect the power contacts and remove the rubber protection «C».
2. Remove the retaining clip «D» and slide off the bulb.

To replace the tail light bulb:

1. Slide off the rubber bulb holder «E» from its seat.

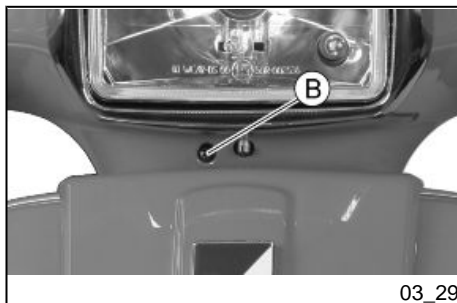

03_29

2. Hold and slide off the bulb.

N.B.

IF MISTING IS NOTICED ON THE INSIDE OF THE HEADLAMP GLASS, THIS DOES NOT INDICATE A FAULT AND IS ATTRIBUTABLE TO HUMIDITY AND/OR TO LOW TEMPERATURES.

THE PHENOMENON SHOULD QUICKLY DISAPPEAR WHEN THE LIGHT IS SWITCHED ON.

THE PRESENCE OF DROPS OF WATER, ON THE OTHER HAND, COULD INDICATE THAT WATER IS INFILTRATING. CONTACT THE AFTER-SALES SERVICE NETWORK.

CAUTION



DO NOT CARRY ANY GARMENTS ON THE FRONT HEADLIGHT ASSEMBLY. THIS MAY CAUSE BULBS TO OVERHEAT AND THEREFORE ABNORMAL WEAR.

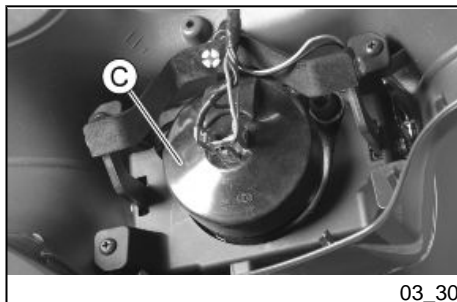

03_30

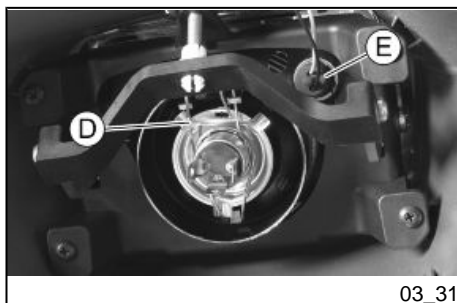

03_31

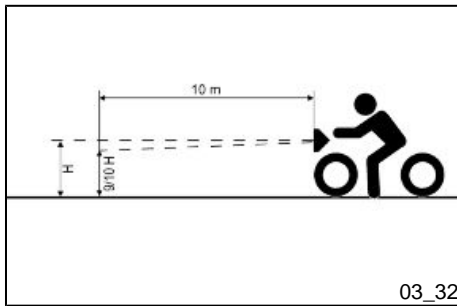

03_32

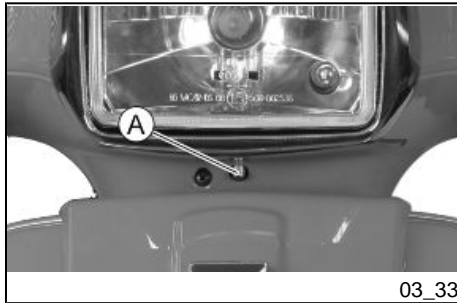

03_33

Headlight adjustment (03_32, 03_33)

Proceed as follows:

- Position the vehicle in running order and with the tyres inflated to the prescribed pressure, onto a flat surface, 10 m away from a half-lit white screen; ensure that the longitudinal axis of the vehicle is perpendicular to the screen;
- Turn on the headlight and check that the borderline of the projected light beam on the screen is not higher than 9/10 or lower than 7/10 of the distance from the ground to the centre of the vehicle headlamp;
- Otherwise, adjust the right headlight with the screw «A».

N.B.

THE ABOVE PROCEDURE COMPLIES WITH THE EUROPEAN STANDARDS REGARDING MAXIMUM AND MINIMUM HEIGHT OF LIGHT BEAMS. REFER TO THE STATUTORY REGULATIONS IN FORCE IN EVERY COUNTRY WHERE THE VEHICLE IS USED.

CAUTION



DO NOT CARRY ANY GARMENTS ON THE FRONT HEADLIGHT ASSEMBLY. THIS MAY CAUSE BULBS TO OVERHEAT AND THEREFORE ABNORMAL WEAR.

Front direction indicators (03_34, 03_35)

To replace the bulbs:

1. Remove the turn indicator from its fitting by undoing the screw «A».
2. Take out the bulb holder «B» from its fitting by turning it anticlockwise.
3. Press the bulb, turn it anticlockwise and then take it out.

To refit, proceed in reverse order.

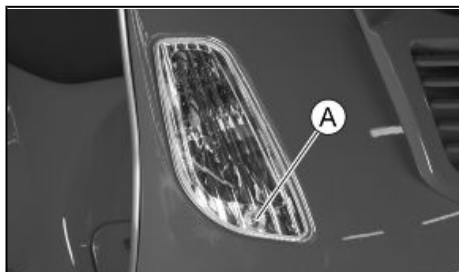

03_34

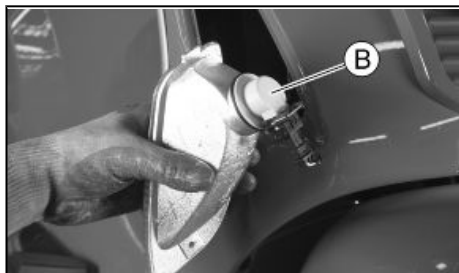

03_35

Rear optical unit (03_36, 03_37)

To replace the taillight bulb:

1. Remove the two screws «A».
2. Take out the bulb holder «B» from its fitting by turning it anticlockwise.
3. Press the bulb, turn it anticlockwise and then take it out.

To refit, proceed in reverse order.

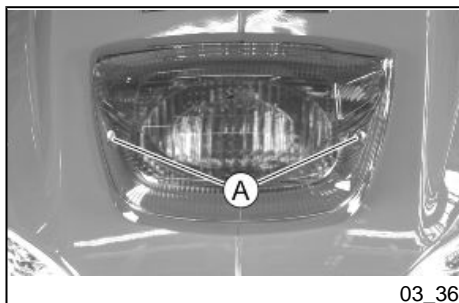

03_36

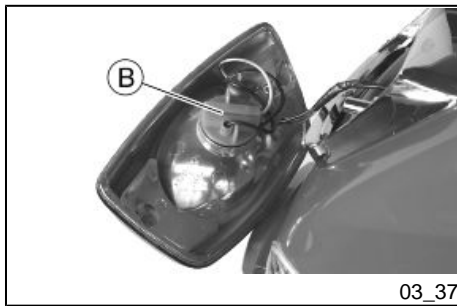

03_37

N.B.

IF MISTING IS NOTICED ON THE INSIDE OF THE HEADLAMP GLASS, THIS DOES NOT INDICATE A FAULT AND IS ATTRIBUTABLE TO HUMIDITY AND/OR TO LOW TEMPERATURES.

THE PHENOMENON SHOULD QUICKLY DISAPPEAR WHEN THE LIGHT IS SWITCHED ON.

THE PRESENCE OF DROPS OF WATER, ON THE OTHER HAND, COULD INDICATE THAT WATER IS INFILTRATING. CONTACT THE AFTER-SALES SERVICE NETWORK.

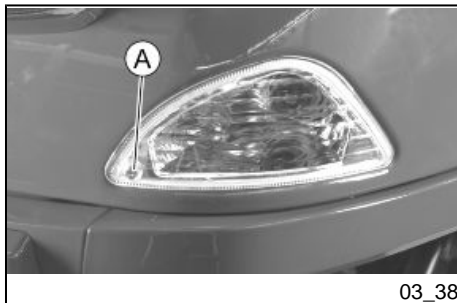

03_38

Rear turn indicators (03_38, 03_39)

To replace the bulbs:

1. Remove the turn indicator from its fitting by undoing the screw «A».
2. Take out the bulb holder «B» from its fitting by turning it anticlockwise.
3. Press the bulb, turn it anticlockwise and then take it out.

To refit, proceed in reverse order.

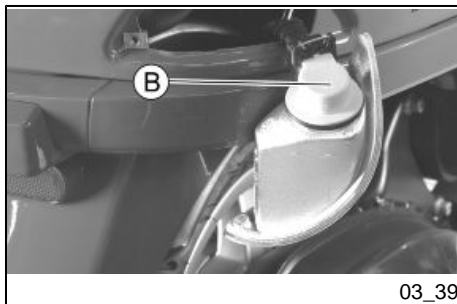

03_39

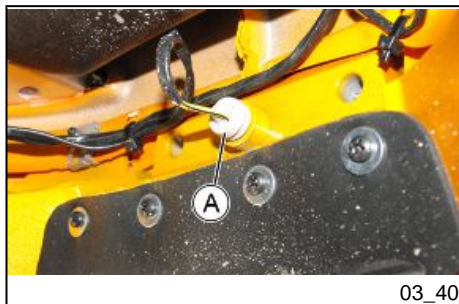

Number plate light (03_40, 03_41)

To remove the license plate bulb proceed as follows:

- Slide off the bulb holder «A» from its seat by operating from the inside of the license plate holder.
- Slide off bulb «B».

CAUTION



DO NOT PULL THE ELECTRICAL WIRING TO EXTRACT THE BULB HOLDER.

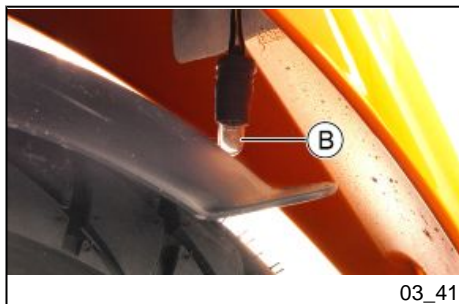

Rear-view mirrors (03_42)

The mirrors can be set to the desired position by adjusting the mirror frame.

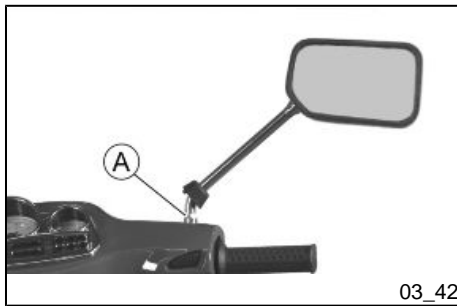

03_42

To remove the rear view mirror unscrew the nut «A» and turn the rear-view mirror supporting stem anticlockwise.



03_43

Front disc brake (03_43)

The brake disc and pad wear is automatically compensated, therefore it has no effect on the functioning of the front and rear brakes. For this reason it is not necessary to adjust the brakes. An excessively elastic brake lever stroke may indicate the presence of air in the braking circuit or a failure in the braking system. In this case, mainly due to the importance of brakes to guarantee safe riding conditions, the vehicle should be taken to an **Authorised Service Centre or Dealer**.

CAUTION



BRAKING SHOULD BEGIN AFTER ABOUT 1/3 OF THE BRAKE LEVER STROKE.

CAUTION



HAVE THE BRAKE PADS CHECKED BY THE DEALER ACCORDING TO THE CHECKS SPECIFIED IN THE SCHEDULED MAINTENANCE TABLE. HOWEVER, IN THE EVENT OF NOISES COMING FROM THE FRONT AND/OR REAR BRAKING SYSTEM DURING OPERATION, IT IS ADVISABLE TO HAVE THE BRAKING SYSTEM CHECKED BY AN AUTHORISED SERVICE CENTRE OR DEALER. AF-

TER REPLACING THE BRAKE PADS, DO NOT USE THE SCOOTER UNTIL YOU HAVE OPERATED THE BRAKE LEVER SEVERAL TIMES IN ORDER TO ALLOW THE PLUNGERS TO SETTLE AND THE LEVER STROKE TO BE SET TO THE CORRECT POSITION.

CAUTION



THE PRESENCE OF SAND, MUD, SNOW MIXED WITH SALT, ETC. ON THE ROAD, CAN DRASTICALLY REDUCE THE LIFE OF THE BRAKE PADS. IN ORDER TO AVOID THIS, WE RECOMMEND WASHING THE VEHICLE FREQUENTLY WHEN RIDING IN THESE ROAD CONDITIONS.

Rear drum brake (03_44)

Operate adjusting nut «B» and loosen lock nut «A» shown in the figure. Note that when the throttle is in idle **the wheel should rotate free**. After the adjustment, screw lock nut «A».

CAUTION



BRAKING SHOULD BEGIN AFTER ABOUT 1/3 OF THE BRAKE LEVER STROKE.

Puncture

The vehicle is equipped with Tubeless tyres (without inner tube). In the event of a puncture, Tubeless tyres - unlike tyres with inner tubes - go flat very slowly, resulting in a greater steering safety. In the event of a puncture, an emergency repair can be carried out using an "inflate and repair" spray can. For a final repair, take your vehicle to an **Authorised Service Centre or Dealer**. The replacement of a tyre involves re-

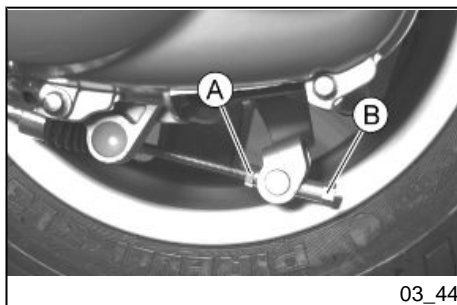

03_44

moving the wheel in question. Take your vehicle to an **Authorised Service Centre or Dealer** for these operations.

CAUTION



TO USE THE "INFLATE AND REPAIR" SPRAY CAN PROPERLY, FOLLOW THE INSTRUCTIONS ON THE PACKAGING.

WARNING



THE WHEELS FITTED WITH TYRES SHOULD ALWAYS BE BALANCED. RIDING THE VEHICLE WITH VERY LOW TYRE PRESSURE OR WITH INCORRECTLY BALANCED TYRES CAN LEAD TO DANGEROUS STEERING VIBRATIONS.



Periods of inactivity (03_45)

We recommend carrying out the following operations:

1. Clean the scooter thoroughly and then cover it with a canvas;
2. With engine off and piston at the bottom dead centre, remove the spark plug, add 1÷2 cm³ of oil through its hole (larger amounts are dangerous for the engine itself). Operate the starter button 1-2 times for roughly 1 second to turn the engine over slowly, then insert the spark plug again;
3. Drain all the fuel from the scooter; spread antirust grease on the uncoated metal parts; keep the wheels lifted above the ground by resting the chassis on two wooden wedges;
4. As regards the battery, follow the instructions in the «Battery» section.

Recommended products

AGIP CITY HI TEC 4T

Oil to lubricate flexible transmissions (throttle control)

Oil for 4-stroke engines

Cleaning the vehicle

Use a low pressure jet of water to soften the caked dirt and mud deposited on the painted surfaces. Once softened, sponge off mud and dirt using a car body sponge soaked in a car body shampoo and water solution (2-4% of car shampoo in water). Then rinse with abundant water, and dry with a shammy cloth. For the engine exterior, use petrol, a brush and clean cloths. Petrol can damage paintwork. Remember that any polishing with silicone wax must always be preceded by washing.

CAUTION



DETERGENTS POLLUTE WATER. THEREFORE THE VEHICLE SHOULD BE WASHED IN AN AREA EQUIPPED FOR THE COLLECTION AND PURIFICATION OF THE LIQUIDS USED.

WARNING



NEVER WASH THE VEHICLE IN THE SUN, ESPECIALLY DURING THE SUMMER WHEN THE BODYWORK IS STILL HOT, AS THE SHAMPOO MAY DRY BEFORE BEING RINSED OFF, AND COULD DAMAGE THE PAINTWORK. NEVER USE RAGS SOAKED IN PETROL OR DIESEL OIL TO CLEAN THE PAINTED OR PLASTIC SURFACES, TO PREVENT THEM LOSING THEIR SHINE AND MECHANICAL CHARACTERISTICS.

WARNING



WHEN WASHING THE ENGINE WITH A HIGH-PRESSURE WATER JET:

- ONLY USE FAN SPRAY JETS.
- KEEP NOZZLE AT LEAST 60 CM AWAY FROM THE VEHICLE
- DO NOT USE WATER AT TEMPERATURES ABOVE 40°C.
- DO NOT DIRECT THE JET AT THE CARBURETOR, THE ELECTRIC CABLES, THE COOLING SLITS IN THE TRANSMISSION COVER AND THE SPIRAL COVER.

Troubleshooting

STARTING FAILURE

Fuse blown	Replace the blown fuse and have the vehicle checked by an Authorised Service Centre .
------------	--

STARTING DIFFICULTIES (SEE «START-UP PROBLEMS» SECTION)

Lack of fuel in tank.	Refuelling
Injection system fault	Contact an Authorised Service Centre

Fuel pump fault	Contact an Authorised Service Centre
Flat battery	Recharge the battery.

**** IMPORTANT: DO NOT USE THE SCOOTER TO THE COMPLETE EXHAUSTION OF FUEL; SHOULD THIS OCCUR, DO NOT ATTEMPT TO START THE ENGINE. TURN THE KEY SWITCH TO «OFF» AND TOP-UP THE FUEL TANK AS SOON AS POSSIBLE. FAILURE TO FOLLOW THESE GUIDELINES COULD DAMAGE THE FUEL PUMP AND/OR THE CATALYTIC CONVERTER.***

IGNITION PROBLEMS

Faulty spark plug	Contact an Authorised Service Centre.
Faulty ignition / injection control unit. Due to the presence of high voltage, this check should only be carried out by an expert.	Contact an Authorised Service Centre

LACK OF COMPRESSION

Loose spark plug.	Screw in the spark plug tightly
Cylinder head loose, piston gas rings worn.	Contact an Authorised Service Centre.
Valve stuck	Contact an Authorised Service Centre.

HIGH CONSUMPTION AND LOW PERFORMANCE

Clogged or dirty air filter

Try to blow out with compressed air, otherwise replace the filter

INSUFFICIENT BRAKING

Greasy disc. Worn pads. Faulty braking system. Presence of air in the front and rear brake circuit.

Contact an **Authorised Service Centre**.

INEFFICIENT SUSPENSION

Shock absorber fault, oil leak, end buffers damaged; shock absorber preloading incorrectly set

Contact an **Authorised Service Centre**.

AUTOMATIC TRANSMISSION PROBLEMS

CVT rollers and/or drive belt damaged

Contact an **Authorised Service Centre**.

Vespa S 125 ie e 150 ie

Vespa®



Chap. 04
Technical data

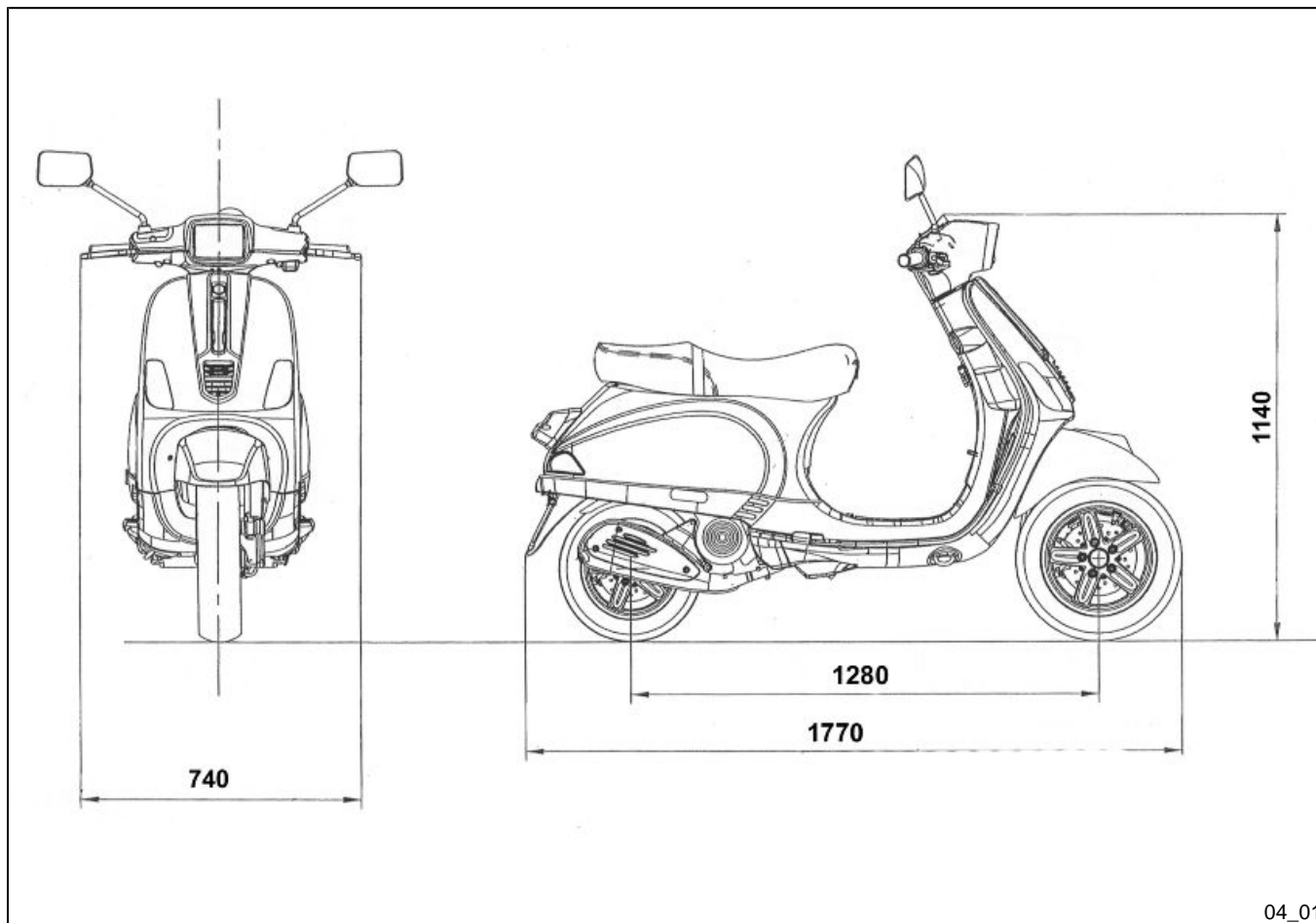

125 cm³ ENGINE SPECIFICATIONS

Type	Single-cylinder, 4-stroke
Engine capacity	124 cm ³
Bore x stroke	57.0 x 48.6 mm
Max. power	7.9 kW at 8,250 rpm
MAX. torque	9.6 Nm at 6,500 rpm
Compression ratio	10.6 ± 0.5: 1
Valve clearance	intake 0.10 exhaust 0.15
Timing system	2 valves, single overhead camshaft, chain driven.
Transmission	Automatic expandable pulley variator with torque server, V-belt, self-ventilating dry automatic centrifugal clutch and transmission housing with forced-circulation air cooling.
Final reduction gear	Gear reduction unit in oil bath.
Lubrication	Engine lubrication with lobe pump (inside crankcase), chain-driven, with double filter: mesh and paper.
Cooling	Forced-air circulation cooling.
Start-up	Electric

Ignition	Electronic inductive discharge ignition, with variable advance and separate HV coil.
Ignition advance	Three-dimensional map managed by control unit
Spark plug (125cc)	NGK CR8EB
Electrode gap	0.7 to 0.8 mm
Fuel system	Electronic injection with Ø 28 mm throttle body, single injector
Fuel	Unleaded petrol (95 RON)
Exhaust silencer	Absorption-type exhaust muffler with catalytic converter.
Emission regulations	EURO 3

150 cm³ ENGINE SPECIFICATIONS

Type	Single-cylinder, 4-stroke
Engine capacity	151 cm ³
Bore x stroke	62.8 x 48.6 mm
Max. power	8.9 kW at 8.000 rpm
MAX. torque	11.8 Nm at 6,250 rpm
Compression ratio	10.6 ± 0.5: 1
Valve clearance	intake 0.10 exhaust 0.15

Timing system	2 valves, single overhead camshaft, chain driven.
Transmission	Automatic expandable pulley variator with torque server, V-belt, self-ventilating dry automatic centrifugal clutch and transmission housing with forced-circulation air cooling.
Final reduction gear	Gear reduction unit in oil bath.
Lubrication	Engine lubrication with lobe pump (inside crankcase), chain-driven, with double filter: mesh and paper.
Cooling	Forced-air circulation cooling.
Start-up	Electric
Ignition	Electronic inductive discharge ignition, with variable advance and separate HV coil.
Ignition advance	Three-dimensional map managed by control unit
Spark plug (150cc)	NGK CR7EB
Electrode gap	0.7 to 0.8 mm
Fuel system	Electronic injection with Ø 28 mm throttle body, single injector
Fuel	Unleaded petrol (95 RON)
Exhaust silencer	Absorption-type exhaust muffler with catalytic converter.
Emission regulations	EURO 3

VEHICLE TECHNICAL DATA

Chassis	Stamped plate body with welded structural reinforcements.
Front suspension	Single arm with helical spring and single double-acting hydraulic shock absorber.
Rear suspension	Double-acting shock absorber, adjustable to four positions at preloading.
Front brake	Ø 200-mm disc brake with hydraulic control activated by handlebar right-side lever.
Rear brake	Ø 110-mm drum brake with mechanical control activated by handlebar left-side lever.
Wheel rim type	Light alloy wheel rims.
Front wheel rim	11" x 2.50
Rear wheel rim	10" x 3.00
Front tyre	Tubeless, 110/70 - 11" 45L
Rear tyre	Tubeless, 120/70 - 10" 54L
Front tyre pressure (with passenger)	1.6 bar (1.6 bar)
Rear tyre pressure (with passenger)	2.0 bar (2.3 bar)
Kerb weight	114 ± 5 kg
Maximum weight allowed	300 kg
Battery	Sealed, 12 V / 10 Ah

CAPACITY

Engine oil	~ 1.100 cm ³
Hub oil	~ 100 cm ³
Fuel tank (reserve)	~8.3 ± 0.5 l (~2.5 l)

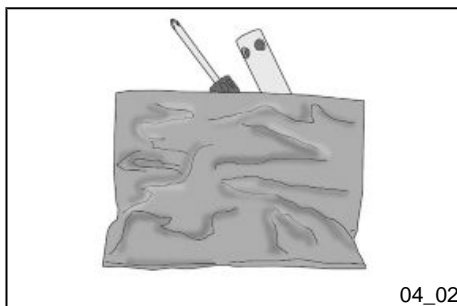
**Kit equipment (04_02)**

The toolkit comprises:

- One box-spanner.
- One twin screwdriver.
- One special spanner for adjusting rear shock absorbers.

The tools are stored in the helmet compartment.

Vespa S 125 ie e 150 ie



Chap. 05 Spare parts and accessories



Warnings (05_01)

WARNING



IT IS RECOMMENDED THAT "ORIGINAL PIAGGIO SPARE PARTS" BE USED, AS THESE ARE THE ONLY ONES OFFERING YOU THE SAME QUALITY ASSURANCE AS THOSE INITIALLY FITTED ON THE VEHICLE.

IT SHOULD BE REMEMBERED THAT USING NON-ORIGINAL SPARE PARTS CAUSES YOUR WARRANTY RIGHTS TO EXPIRE.

WARNING



PIAGGIO MARKETS ITS OWN LINE OF ACCESSORIES THAT ARE RECOGNISED AND GUARANTEED FOR USE. IT IS THEREFORE ESSENTIAL TO CONTACT AN AUTHORISED DEALER OR SERVICE CENTRE IN ORDER TO CHOOSE AND FIT ACCESSORIES CORRECTLY. THE USE OF NON-ORIGINAL ACCESSORIES MAY AFFECT THE STABILITY AND OPERATION OF YOUR VEHICLE AND REDUCE SAFETY LEVELS WITH POTENTIAL RISKS FOR THE RIDER.

Vespa S 125 ie e 150 ie



Chap. 06 Programmed maintenance



Scheduled maintenance table (06_01)

Adequate maintenance is fundamental to ensure long-lasting, optimum operation and performance of your vehicle.

To this end, a series of checks and maintenance operations (at the owner's expense) have been suggested, which are included in the summary table on the following page. Any minor faults should be reported without delay to an **Authorised Service Centre or Dealer** without waiting until the next scheduled service to solve it.

All scheduled maintenance services must be carried out at the specified intervals, even if the stated mileage has not yet been reached. Punctual scooter servicing is essential to ensure your warranty remains valid. For any further information concerning Warranty procedures and 'Scheduled Maintenance', please refer to the 'Warranty Booklet'.

MAINTENANCE TABLE

Km x 1,000	1	6	12	18	24	30	36	42	48	54	60
Safety locks	I		I		I		I		I		I
Spark plug		I	R	I	R	I	R	I	R	I	R
Centre stand		L	L	L	L	L	L	L	L	L	L
Driving belt		I	R	I	R	I	R	I	R	I	R
Throttle control	A		A		A		A		A		A
Air filter		C	C	C	C	C	C	C	C	C	C
Oil filter		R	R	R	R	R	R	R	R	R	R
Mesh oil filter	C	C	C	C	C	C	C	C	C	C	C
Valve clearance		A		A			A			A	
Electrical system and battery	I	I	I	I	I	I	I	I	I	I	I

Km x 1,000	1	6	12	18	24	30	36	42	48	54	60
Cylinder ventilation system					C				C		
Brake control levers	L		L		L		L		L		L
Brake fluid **	I	I	I	I	I	I	I	I	I	I	I
Engine oil *	R	R	R	R	R	R	R	R	R	R	R
Hub oil	R	I	I	I	R	I	I	I	R	I	I
Headlight aiming adjustment			A		A		A		A		A
Brake pads	I	I	I	I	I	I	I	I	I	I	I
Sliding blocks / variable speed rollers		I	R	I	R	I	R	I	R	I	R
Tyre pressure and wear	I	I	I	I	I	I	I	I	I	I	I
Vehicle test ride	I	I	I	I	I	I	I	I	I	I	I
Odometer gear			L		L		L		L		L
Suspension			I		I		I		I		I
Steering	A		A		A		A		A		A
Transmissions			L		L		L		L		L

I: INSPECT AND CLEAN, ADJUST, LUBRICATE OR REPLACE, IF NECESSARY

C: CLEAN, **R:** REPLACE, **A:** ADJUST, **L:** LUBRICATE

* Check level every 3,000 km

** Replace every 2 years

RECOMMENDED PRODUCTS TABLE

Product	Description	Specifications
AGIP ROTRA 80W-90	Rear hub oil	SAE 80W/90 Oil that exceeds the requirements of API GL3 specifications
AGIP BRAKE 4	Brake fluid	FMVSS DOT 4 Synthetic fluid
AGIP CITY HI TEC 4T	Oil to lubricate flexible transmissions (brakes, throttle control and odometer)	Oil for 4-stroke engines
AGIP FILTER OIL	Oil for air filter sponge	Mineral oil with specific additives for increased adhesiveness
AGIP CITY HI TEC 4T	Engine oil	SAE 5W-40, API SL, ACEA A3, JASO MA Synthetic oil
AGIP GREASE MU3	Grease for odometer transmission gear case	Soap-based lithium grease with NLGI 3; ISO-L-XBCHA3, DIN K3K-20
AGIP GP 330	Grease for brake control levers, throttle, stand	White calcium complex soap-based spray grease with NLGI 2; ISO-L-XBCIB2

TABLE OF CONTENTS

A

Air filter: 41, 42

B

Battery: 44, 46
Brake: 43, 58, 59

C

Checks: 22
Clock: 11

D

Disc brake: 58

E

Engine oil: 34, 35

F

Fuel: 16
Fuses: 48

H

Headlight: 54
Horn: 14
Hub oil: 37

I

Identification: 17
Instrument panel: 10

K

Key switch: 12
Keys: 17

L

Light switch: 15

M

Maintenance: 33, 75, 76
Mirrors: 57

P

Puncture: 59

R

Refuelling: 22

S

Saddle: 16
Scheduled maintenance: 76
Shock absorbers: 24
Spark plug: 40
Stand: 29
Start-up: 15
Switch: 12, 14, 15

T

Tank: 16
Technical Data: 65
Transmission: 30
Turn indicators: 56
Tyre pressure: 23
Tyres: 39

V

Vehicle: 7, 61



The descriptions and illustrations given in this publication are not binding. While the basic specifications as described and illustrated in this manual remain unchanged, PIAGGIO-GILERA reserves the right, at any time and without being required to update this publication beforehand, to make any changes to components, parts or accessories, which it considers necessary to improve the product or which are required for manufacturing or construction reasons.

Not all versions/models shown in this publication are available in all countries. The availability of each model should be checked at the official Piaggio sales network.

"© Copyright 2008 - PIAGGIO & C. S.p.A. Pontedera. All rights reserved. Reproduction of this publication in whole or in part is prohibited."

PIAGGIO & C. S.p.A. - After-Sales

V.le Rinaldo Piaggio, 23 - 56025 PONTEDERA (Pi)