

Vespa would like to thank you

for choosing one of its products. We have prepared this manual to help you to get the very best from your vehicle. Please read it carefully before riding the vehicle for the first time. It contains information, tips and precautions for using your vehicle. It also describes features, details and devices to assure you that you have made the right choice. We believe that if you follow our suggestions, you will soon get to know your new scooter and it will serve you well for a long time to come. This booklet forms an integral part of the vehicle; should the vehicle be sold, it must be transferred to the new owner.

Vespa S 150



The instructions given in this manual are intended to provide a clear, simple guide to using your vehicle; this booklet also details routine maintenance procedures and regular checks that should be carried out on the vehicle at an **authorised Dealer or Service Centre**. The booklet also contains instructions for simple repairs. Any operations not specifically described in this booklet require the use of special tools and/or particular technical knowledge: to carry out these operations, refer to any **authorised Dealer or Service Centres**.



Personal safety

Failure to completely observe these instructions will result in serious risk of personal injury.



Safeguarding the environment

Sections marked with this symbol indicate the correct use of the vehicle to prevent damaging the environment.



Vehicle intactness

The incomplete or non-observance of these regulations leads to the risk of serious damage to the vehicle and sometimes even the invalidity of the guarantee.

The signs that you see on this page are very important. They are used to highlight parts of the booklet that should be read with particular care. The different symbols are used to make each topic in the manual simple and quick to locate.

INDEX

VEHICLE	7	Engine oil level check.....	34
Dashboard.....	9	Engine oil top-up.....	35
Analogue instrument panel.....	11	Warning light (insufficient oil pressure).....	35
Clock.....	11	Engine oil change.....	35
Keyswitch.....	12	Hub oil level.....	37
Locking the steering wheel.....	13	Tyres.....	38
Releasing the steering wheel.....	13	Spark plug dismantlement.....	39
Switch direction indicators.....	13	Removing the air filter.....	41
Horn button.....	14	Air filter cleaning.....	41
Light switch.....	14	Secondary air system.....	42
Start-up button.....	15	Checking the brake oil level.....	43
Fuel tank.....	15	Braking system fluid top up.....	43
Opening the saddle.....	16	Battery.....	45
Keys.....	16	Use of a new battery.....	45
Identification.....	16	Long periods of inactivity.....	46
Bag clip.....	18	Fuses.....	48
USE	19	Lamps.....	50
Checks.....	20	Front light group.....	52
Refuelling.....	20	Head light adjustment.....	53
Tyre pressure.....	21	Front direction indicators.....	54
Shock absorbers adjustment.....	22	Rear optical unit.....	55
Running in.....	23	Rear turn indicators.....	55
Starting up the engine.....	23	Number plate light.....	56
Precautions.....	25	Rear-view mirrors.....	56
Difficult start up.....	25	Idle adjustment.....	57
Stopping the engine.....	26	Front disc brake.....	58
Anti-theft ring.....	27	Rear drum brake.....	59
Catalytic silencer.....	27	Puncture.....	59
Stand.....	28	Inactivity of the vehicle.....	60
Automatic transmission.....	29	Cleaning the vehicle.....	61
Safe driving.....	29	Troubleshooting.....	63
MAINTENANCE	33	TECHNICAL DATA	67
Engine oil level.....	34	Tool kit.....	72

SPARE PARTS AND ACCESSORIES	73
Warnings.....	74
SCHEDULED MAINTENANCE	75
Scheduled servicing table.....	76

Vespa S 150

Vespa[®]



**Chap. 01
Vehicle**

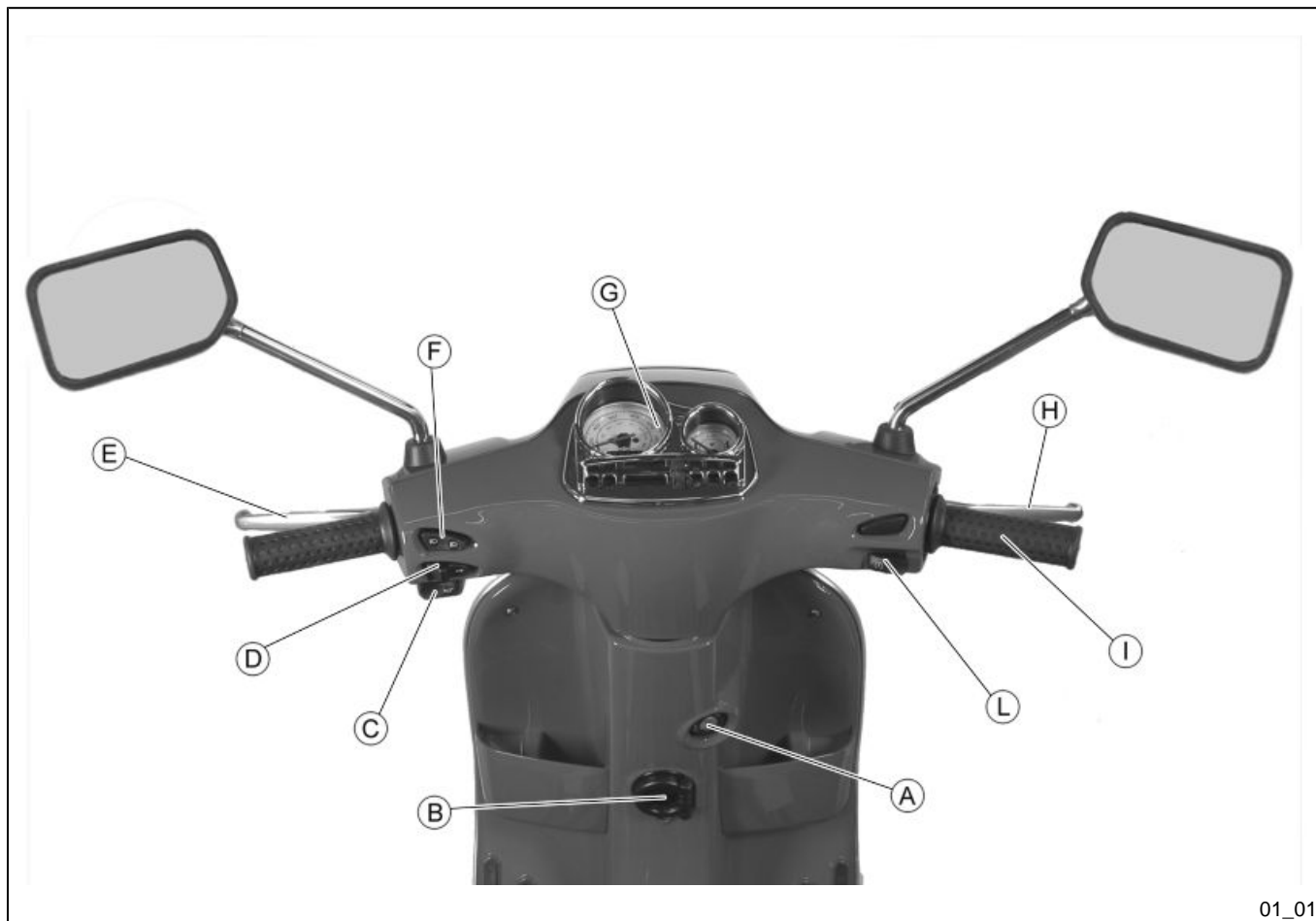

Dashboard (01_01)

A = Ignition key-switch

B = Bag hook

C = Horn button

D = Turn indicator switch

E = Rear brake lever

F = Headlight switch

G = Analogue instrument panel

H = Front brake lever

I = Throttle grip

L = Starter button

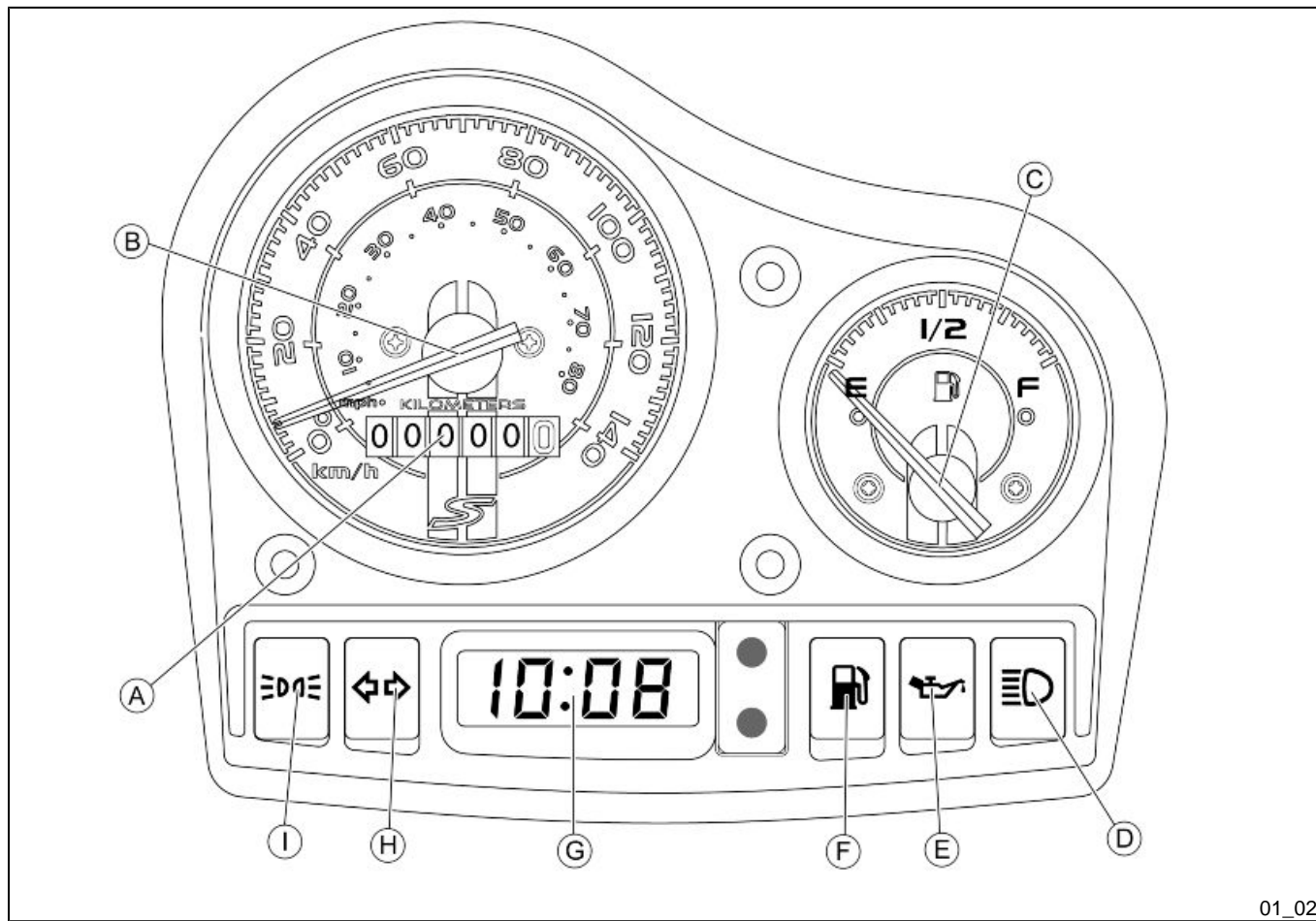

Analogue instrument panel (01_02)

A = Odometer

B = Speedometer

C = Fuel gauge

D = High-beam warning light

E = Low oil pressure warning light

F = Fuel level warning light

G = Digital clock

H = Turn indicator warning light

I = Headlight warning light

Clock (01_03)

Located in the instrument panel, it displays hours and minutes with 1 to 12-hour time, AM or PM.

Operate the function selection button «**B**» and month, day and seconds are also displayed besides hours and minutes.

To adjust the different functions, select the desired function with button «**A**» and adjust with button «**B**». The time counter can be reset by pressing button «**A**» with the clock in the seconds function.

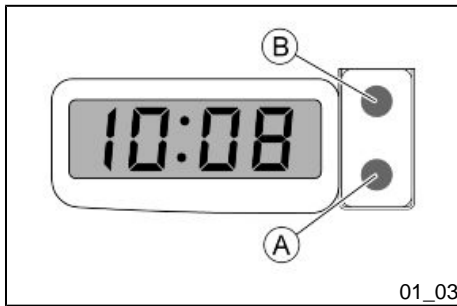

The digital clock is powered by a battery (battery life is about 2 years); lift the whole instrument panel to replace the battery. It is advisable to take your vehicle to an **Authorised Service Centre** for this operation.

WARNING



DEAD BATTERIES ARE HARMFUL TO THE ENVIRONMENT. THEY MUST DISPOSED OF IN SUITABLE CONTAINERS AS PRESCRIBED BY THE REGULATIONS IN FORCE.

Keyswitch (01_04)

Ignition key «A» is located on the front leg shield back plate near the bag hook.

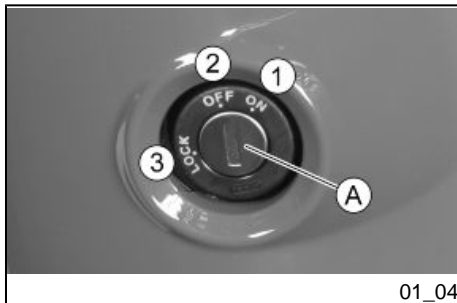

SWITCH POSITIONS

ON «1»: Ready to start position, non-extractable key, mechanical antitheft device disabled.

OFF «2»: Ignition disabled, extractable key, mechanical antitheft device disabled.

LOCK «3»: Ignition disabled, extractable key, mechanical antitheft device enabled.

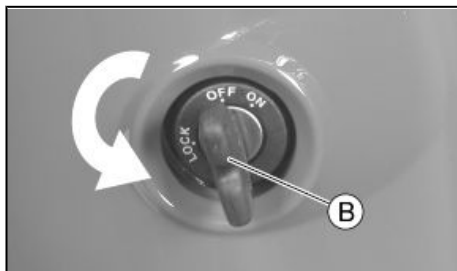

01_05

Locking the steering wheel (01_05)

Turn the handlebar to the left as far as it will go; turn the key «B» to «LOCK» and remove it.

CAUTION



NEVER TURN THE KEY TO «LOCK» OR «OFF» WHILE RIDING.

Releasing the steering wheel

Reinsert the key «B» and turn it to «KEY OFF».

CAUTION



NEVER TURN THE KEY TO «LOCK» OR «OFF» WHILE RIDING.

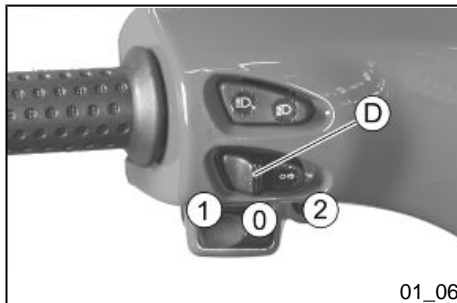

01_06

Switch direction indicators (01_06)

Lever «D» towards «1» = left turn indicators switched on;

Lever «D» towards «2» = right turn indicators switched on;

The lever «D» automatically goes back to «0» and the turn indicators remain on; push the lever «D» to turn them off.

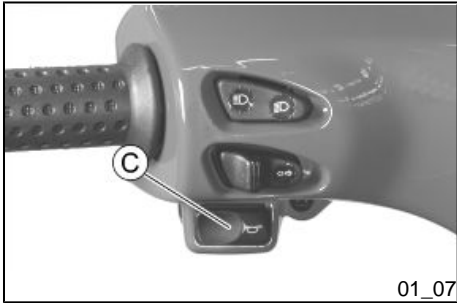

Horn button (01_07)

Push the «C» button to sound the horn.

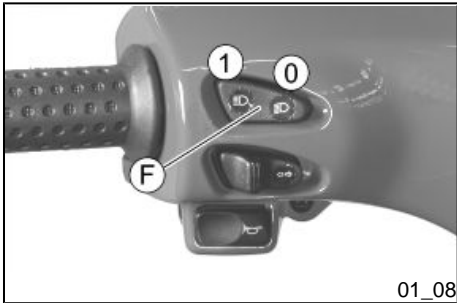

Light switch (01_08)

When the light switch «F» is set to «0», the low-beam light is on. When set to «1», the high-beam light is activated.

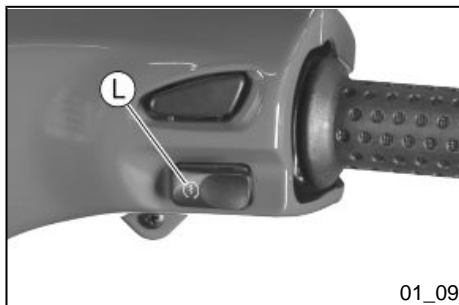

Start-up button (01_09)

To start the engine, pull either of the two brake levers and then push the button «L».

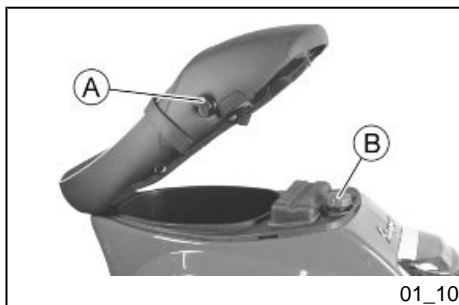

Fuel tank (01_10)

The fuel tank cap «B» is under the saddle. To reach it, insert the key into lock «A», turn it anticlockwise and tip the saddle forwards.

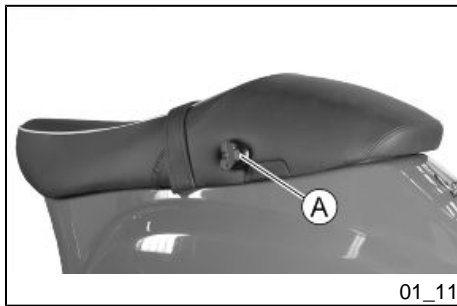

Opening the saddle (01_11)

Insert the key into the saddle lock «A», turn it anticlockwise and tip the saddle forward.



Keys (01_12)

The vehicle is supplied with two keys (one spare) which serve to start the engine and unlock the saddle compartment. The keys are accompanied by a tag marked with the identification code to be quoted when ordering duplicates.

WARNING

WE RECOMMEND KEEPING THE DUPLICATE KEY TOGETHER WITH ITS CODE IN A SAFE PLACE AND NOT ON THE VEHICLE

Identification (01_13, 01_14)

Identification registration numbers are made up of a prefix and a number, stamped on the chassis and on the engine. These numbers must always be quoted when ordering spare parts. We recommend checking that the chassis registration number stamped on the vehicle corresponds with that on the vehicle documentation.

CAUTION

BE REMINDED THAT ALTERING IDENTIFICATION REGISTRATION NUMBERS CAN LEAD TO SERIOUS PENAL SANCTIONS (IMPOUNDING OF THE VEHICLE, ETC.).

Chassis number

The number «**A**» is stamped near the battery compartment. Remove the helmet compartment to read it.

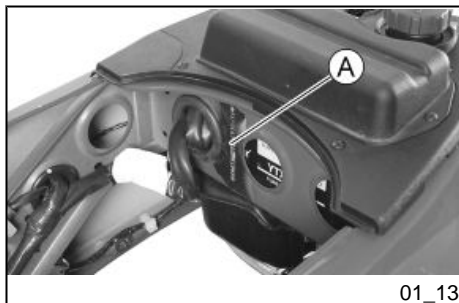

01_13

Engine number

The engine number «**B**» is stamped near the rear left shock absorber lower support.

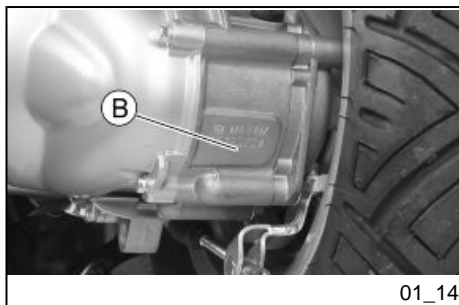

01_14

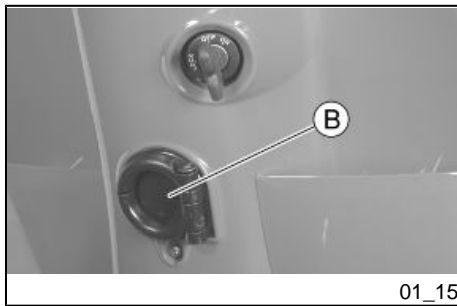

Bag clip (01_15)

To use the retractable bag hook «B» mounted on the leg shield back plate, pull it slightly towards the back of the vehicle.

Vespa S 150

Vespa®



Chap. 02
Use

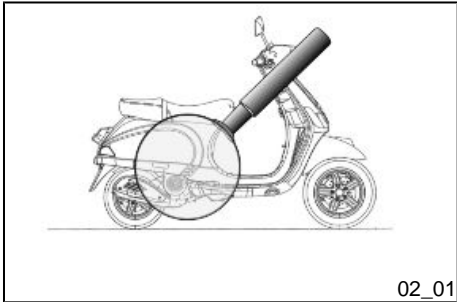

Checks (02_01)

Before using the vehicle, check:

1. That the fuel tank is full.
2. Rear hub oil level.
3. The engine oil level.
4. That the tyres are properly inflated.
5. The correct functioning of the headlights, tail light, turn indicators, stop light and license plate light.
6. The correct functioning of front and rear brakes.
7. That the front brake fluid level is correct.

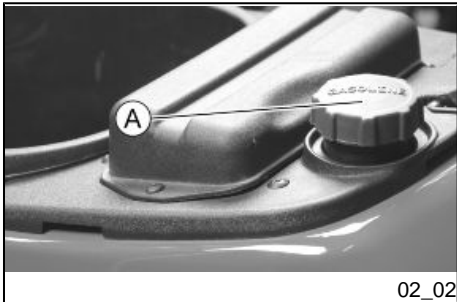

Refuelling (02_02)

Reach the fuel tank and unscrew the cap «A».

Use premium unleaded petrol, with minimum octane rating of 95.

A specific gauge on the instrument panel indicates the fuel level.

WARNING



SWITCH OFF THE ENGINE BEFORE REFUELLING WITH PETROL.

PETROL IS HIGHLY INFLAMMABLE.

DO NOT SMOKE AND KEEP NAKED FLAMES AT A DISTANCE: FIRE HAZARD.

DO NOT INHALE FUEL FUMES.

DO NOT ALLOW PETROL TO COME INTO CONTACT WITH HOT ENGINE OR ANY PLASTIC PARTS.

CAUTION



PETROL DAMAGES THE PLASTIC PARTS OF THE BODYWORK.

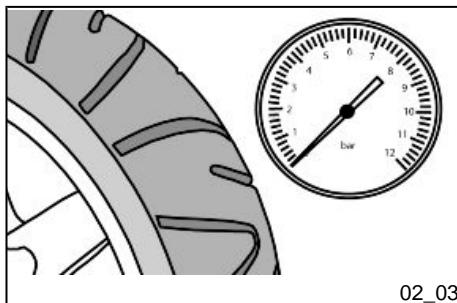

Tyre pressure (02_03)

Check tyre pressure as indicated in the scheduled maintenance table.

CAUTION



TYRE PRESSURE SHOULD BE CHECKED WHEN TYRES ARE COLD. INCORRECT TYRE PRESSURE CAUSES ABNORMAL TYRE WEAR AND MAKES RIDING DANGEROUS.

TYRES MUST BE REPLACED WHEN THE TREAD REACHES THE WEAR LIMITS SET FORTH BY LAW.

TYRE INFLATION PRESSURE

Front tyre pressure (with passenger)	1.6 bar (1.6 bar)
Rear tyre pressure (with passenger)	2.0 bar (2.3 bar)

TYRES

Front tyre	Tubeless, 110/70 - 11" 45L
Rear tyre	Tubeless, 120/70 - 10" 54L

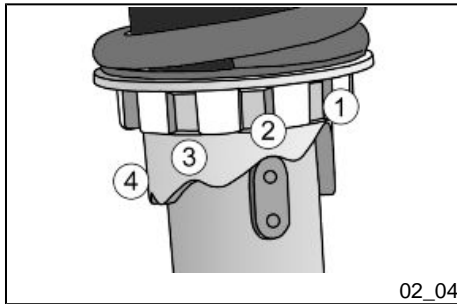

Shock absorbers adjustment (02_04, 02_05)

The preloading of the spring can be adjusted to 4 positions using the ring nut located in the lower part of the shock absorbers and the specific spanner supplied.

Position 1: minimum preload: rider only

Position 2 medium preloading: rider only

Position 3 medium preloading: rider and passenger

Position 4: maximum preloading: rider, passenger, and luggage.

In order to carry out this operation you will need to use the specific spanner in the kit. Spring preloading increases by turning the ring nut towards «A», but decreases if the ring nut is turned towards «B».

CAUTION



RIDING THE VEHICLE WITH THE SPRING PRELOADING NOT CORRECTLY SET FOR THE RIDER AND POSSIBLE PASSENGER, COULD REDUCE THE COMFORT OF THE RIDE AND THE PRECISION OF THE STEERING.

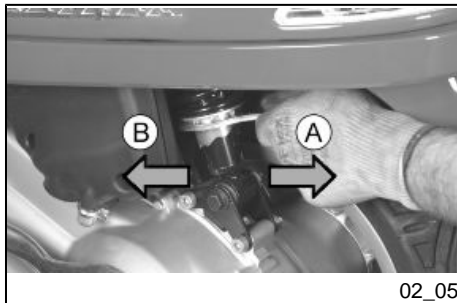

WARNING

WE RECOMMEND WEARING GLOVES WHILE CARRYING OUT THIS OPERATION IN ORDER TO AVOID INJURIES.

Running in (02_06)**WARNING**

DURING THE FIRST 1000 KM DO NOT RIDE THE VEHICLE OVER 80% OF ITS MAXIMUM SPEED. AVOID TWISTING THE THROTTLE GRIP FULLY OR KEEPING A CONSTANT SPEED ALONG LONG SECTIONS OF ROAD. AFTER THE FIRST 1000 KM, GRADUALLY INCREASE SPEED UNTIL REACHING THE MAXIMUM PERFORMANCE.

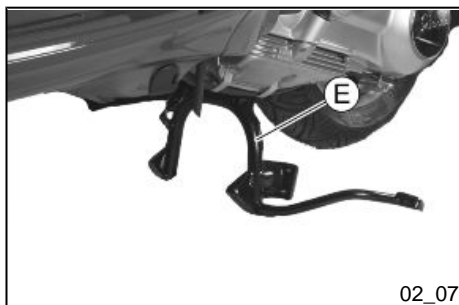
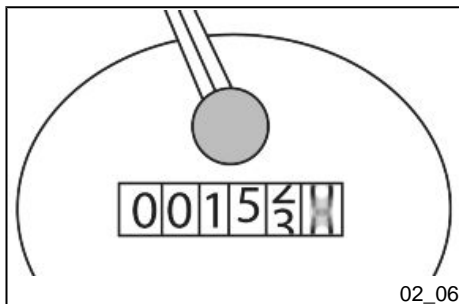
**Starting up the engine (02_07, 02_08, 02_09, 02_10)**

The vehicle is fitted with automatic transmission with a regulator and centrifugal clutch. Therefore always start the engine with the throttle at idle speed; to start-off from stationary position, progressively twist the throttle grip.

The vehicle is equipped with an electric fuel pump and a starter that switch on automatically as soon as the engine is started.

In order to start the vehicle:

1. Place the vehicle on stand «E»; check that the rear wheel is off the ground.
2. Keep the throttle closed.

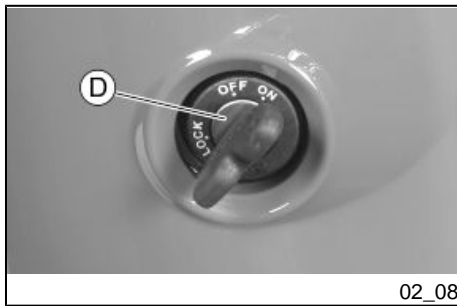

02_08

3. Insert the key into the ignition switch, "D", and turn to the **ON** position.

4. Push the starter button «A» after pulling the rear brake lever «B» or the front brake lever «C».

CAUTION



DO NOT CARRY OUT THESE OPERATIONS IN CLOSED AREAS SINCE EXHAUST GASES ARE TOXIC.

CAUTION



DUE TO THE HIGH TEMPERATURES THE CATALYTIC CONVERTER CAN REACH, ALWAYS TAKE CARE, WHEN PARKING THE VEHICLE, THAT THE SILENCER DOES NOT COME INTO CONTACT WITH FLAMMABLE MATERIALS, TO AVOID SERIOUS BURNS.

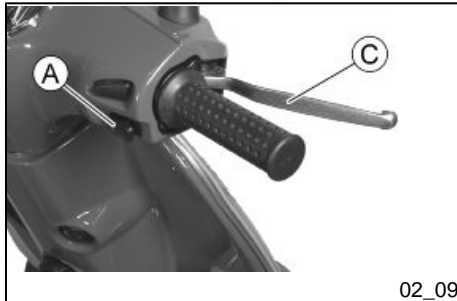

02_09

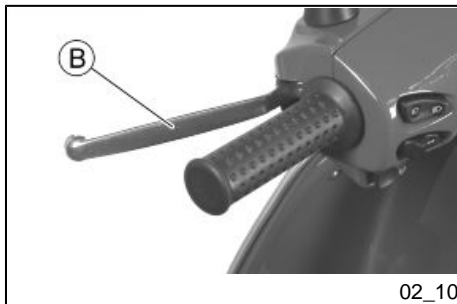

02_10

Precautions

WARNING



NEVER STRESS THE ENGINE AT LOW TEMPERATURES IN ORDER TO AVOID POSSIBLE DAMAGE. BE CAREFUL NEVER TO EXCEED THE MAXIMUM SPEED WHILE RUNNING DOWNHILL, IN ORDER TO AVOID DAMAGING THE ENGINE. IN ANY CASE, IN ORDER TO PRESERVE THE ENGINE FROM PROLONGED OVERREVVING, THE REVOLUTION LIMITER WILL BE ACTIVATED IF THE ENGINE SPEED EXCEEDS THE ESTABLISHED THRESHOLD. DO NOT ACTIVATE THE REVOLUTION LIMITER RECURRENTLY SO AS TO AVOID DAMAGING THE CATALYTIC CONVERTER.

WARNING



AFTER A LONG DISTANCE COVERED AT THE MAXIMUM SPEED, DO NOT STOP THE ENGINE IMMEDIATELY, BUT LET IT RUN AT IDLE FOR A FEW SECONDS.

Difficult start up (02_11, 02_12, 02_13)

If there is a problem you can follow the instructions below:

1. Engine flooded. Place the vehicle on its centre stand and check that the rear wheel is off the ground. Open the throttle fully and press the starter button for five seconds and then stop for five seconds. If the engine does not start after a few attempts, let the engine sit for a few minutes and then repeat the above operations. In any case do not operate the starter motor longer than 20" in an attempt to start the engine.

2. Battery or starter motor inefficiency. Place the scooter on its stand "E"; make sure that the rear wheel is off the ground, turn the key switch «D» to «ON» and use the kick-starter «F». If the kick-starter is not installed in some vehicles, consult any **Authorised Service Centre**.



02_11

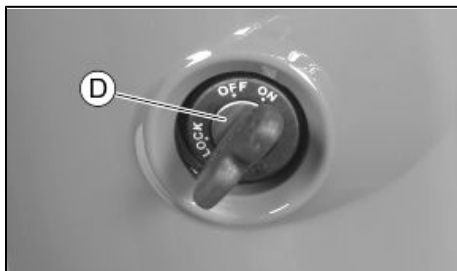

02_12

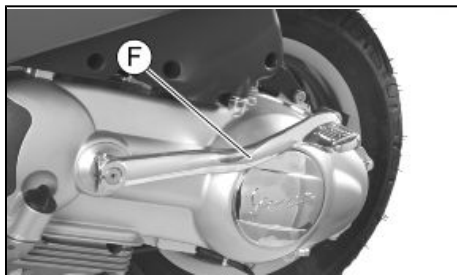

02_13

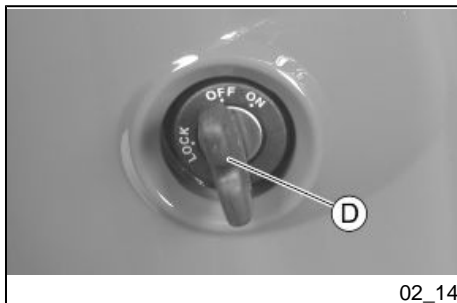

02_14

CAUTION

ALWAYS PLACE THE VEHICLE ON ITS STAND BEFORE KICK STARTING.

WARNING

TAMPERING MAY CAUSE SERIOUS ENGINE MALFUNCTION.

Stopping the engine (02_14)

Stop acceleration, then turn the key switch «D» to «OFF» to stop the engine (extractable key).

CAUTION

DUE TO THE HIGH TEMPERATURES THE CATALYTIC CONVERTER CAN REACH, ALWAYS TAKE CARE, WHEN PARKING THE VEHICLE, THAT THE SI-

LENCER DOES NOT COME INTO CONTACT WITH FLAMMABLE MATERIALS, TO AVOID SERIOUS BURNS.

Anti-theft ring (02_15)

The «D» ring on the right side of the vehicle is used to fasten the vehicle to an object using a scooter chain. Do not use the ring for other purposes.

WARNING



THIS ACCESSORY IS NOT A THEFT PREVENTION GUARANTEE, IT IS ONLY A DETERRENT.

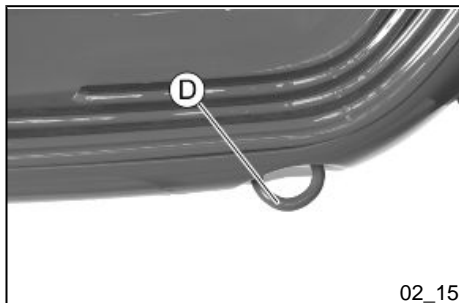

Catalytic silencer (02_16)

CAUTION



TAMPERING WITH THE CATALYTIC SILENCER MAY CAUSE SEVERE DAMAGE TO THE ENGINE.

CAUTION



WHEN PARKING THE VEHICLE, DUE TO THE HIGH TEMPERATURES THE CATALYTIC CONVERTER CAN REACH, ALWAYS BE CAREFUL THAT THE MUF-



FLER DOES NOT COME INTO CONTACT WITH FLAMMABLE MATERIALS, TO AVOID SERIOUS BURNS.

CAUTION



DO NOT SHUT OFF THE ENGINE WHILE THE VEHICLE IS MOVING. UNBURNED FUEL COULD ENTER THE CATALYTIC CONVERTER AND BURN, CAUSING THE CONVERTER TO OVERHEAT AND POSSIBLY DESTROYING IT.

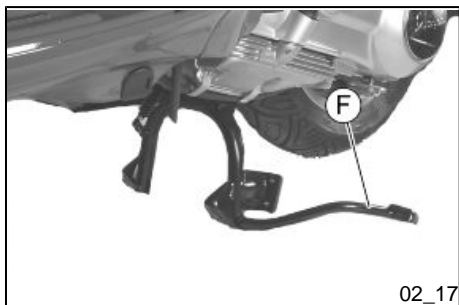

Stand (02_17)

Lower the centre stand «F» by kicking the bracket while pulling the vehicle backward, holding onto the handlebar.



02_18

Automatic transmission (02_18)

To ensure simple, pleasurable riding, the vehicle is equipped with automatic transmission with regulator and centrifugal clutch. The system is designed to give the best possible performance in terms of both acceleration and consumption, on level ground and uphill, thanks to the adjustments made to engine speed and transmitted torque. If you have to stop on an uphill slope (traffic lights, traffic jam, etc.) only use the brake to keep the vehicle still, leaving the motor running at idling speed. Using the motor to keep the vehicle still can cause the clutch to overheat. This problem is due to the friction of the clutch parts on the clutch bell. It is therefore recommended to avoid conditions of prolonged clutch slippage leading to clutch overheating (for example, as well as the situation described above, riding uphill fully laden on steep slopes or starting off on slopes greater than 25%, etc.):

1. Do not continue riding in such conditions.
2. Let the clutch cool down with the motor at idling speed for a few minutes

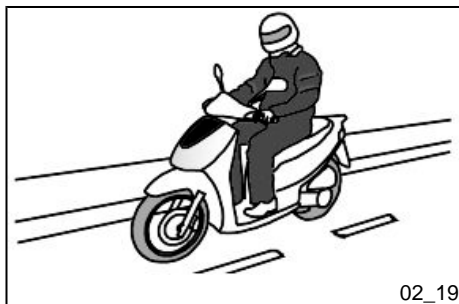

02_19

Safe driving (02_19)

Some simple tips are provided below that will enable you to use your vehicle on a daily basis in greater safety and peace of mind. Your skill and your mechanical knowledge are the basis of a safe ride. We recommend trying out the vehicle in traffic - free zones, in order to acquire a good knowledge of the vehicle itself.

1. Before riding off, remember to put the helmet on and fasten it correctly.
2. Reduce speed on rough roads and ride with care.
3. After riding on a long stretch of wet road without using the brakes, braking can be poor at the beginning. In these conditions, it is a good idea to apply the brakes from time to time.
4. Do not brake hard on wet, unsurfaced or slippery roads.
5. Avoid riding off by mounting the scooter when it is resting on its support. In any case, in order to avoid abrupt departures, the rear wheel should not be turning when it comes into contact with the ground.

6. If the vehicle is used on roads covered with sand, mud, snow mixed with salt, etc., clean the brake disc frequently with a mild detergent in order to prevent abrasive particles from building up inside the holes, which can result in early brake pad wear.

CAUTION

ALWAYS RIDE WITHIN YOUR LIMITS RIDING UNDER THE INFLUENCE OF ALCOHOL OR OTHER DRUGS AND CERTAIN MEDICINES IS EXTREMELY DANGEROUS.

CAUTION

ANY ELABORATION THAT MODIFIES THE VEHICLE'S PERFORMANCES, SUCH AS TAMPERING WITH ORIGINAL STRUCTURAL PARTS IS STRICTLY FORBIDDEN BY LAW, AND RENDERS THE VEHICLE NO LONGER CONFORMING TO THE APPROVED TYPE AND DANGEROUS FOR RIDING.

CAUTION

DO NOT ADJUST THE MIRRORS WHILE RIDING. THIS COULD CAUSE YOU TO LOOSE CONTROL OF THE VEHICLE.

WARNING

IN ORDER TO PREVENT ANY ACCIDENTS RIDE VERY CAREFULLY AFTER ADDING ACCESSORIES AND WHILE CARRYING LUGGAGE. THE ADDITION OF ACCESSORIES AND LUGGAGE CAN REDUCE YOUR SCOOTER STABILITY AND PERFORMANCE, AS WELL AS THE LEVEL OF SAFETY DURING USE. (SEE THE «SPARE PARTS AND ACCESSORIES» SECTION)

Vespa S 150

Vespa®



**Chap. 03
Maintenance**

Engine oil level

In 4T engines, the engine oil is used to lubricate the distribution elements, the bench bearings and the thermal group. **An insufficient quantity of oil can cause serious damage to the engine.** In all four-stroke engines, a loss of efficiency in oil performance and consumption should be considered normal. Consumption can particularly reflect the conditions of use (i.e. when driving at "full acceleration" all the time, oil consumption increases). **In order to prevent any problems, we recommend checking the oil level any time you use the vehicle. The vehicle is, however, equipped with an oil pressure warning light on the instrument panel.**

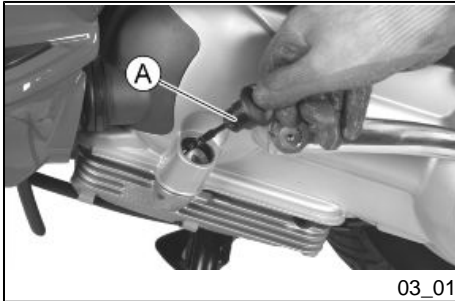

Engine oil level check (03_01, 03_02)

Every time the vehicle is used, visually inspect the level of the engine oil when the engine is cold (after **completely unscrewing** the oil cap/dipstick). The oil level should be somewhere between the MAX and MIN index marks on the level rod; «A»; while the oil is being checked, the vehicle must be resting on its centre stand on an even, horizontal surface.

If the check is carried out after the vehicle has been used, and therefore with a hot engine, the level will be lower; in order to carry out a correct check, wait at least 10 minutes after the engine has been stopped so as to get the correct level.

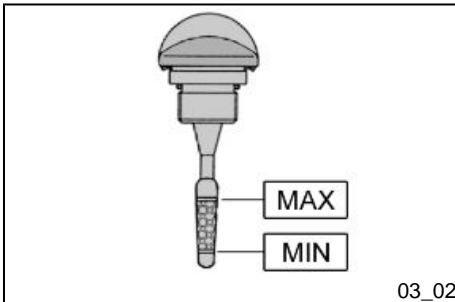

Engine oil top-up

The oil should be topped up after having checked the level and in any case by adding oil **without ever exceeding the MAX. level**. Take your vehicle to an **Authorised Service Centre** to have the engine oil checked and if necessary, topped-up as indicated in the scheduled maintenance table.

Warning light (insufficient oil pressure)

The vehicle is equipped with a warning light that comes on when the key is turned to «ON». However, this light should switch off once the engine has been started. **If the light comes on while braking, at idle speed or while turning a corner, it is necessary to check the oil level and top it up if required. If after having topped-up the oil, the warning light still comes on while braking, at idle speed or while turning a corner, it will be necessary to take your vehicle to an Authorised Service Centre.**

Engine oil change (03_03)

The oil and the cartridge filter «C» must be changed as indicated in the scheduled maintenance tables at an **Authorized Service Centre**. The engine should be emptied by draining the oil from the drainage plug «B» of the gauze filter on the flywheel side. In order to facilitate oil drainage, loosen the cap/dipstick. Since a certain quantity of oil still remains in the circuit, refill with approx. $850 \div 900 \text{ cm}^3$ of oil through the cap «A. Then start up the vehicle, leave it running for a few minutes and switch it off: after 5 minutes, check the level and if necessary, top-up **without exceeding the MAX level**. The cartridge filter must be replaced at every oil change. For top-ups and changes, use new oil of the recommended type.

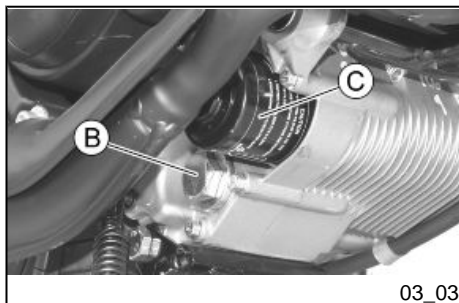

WARNING

RUNNING THE ENGINE WITH INSUFFICIENT LUBRICATION OR WITH INADEQUATE LUBRICANTS ACCELERATES THE WEAR AND TEAR OF THE MOVING PARTS AND CAN CAUSE IRRETRIEVABLE DAMAGE.

WARNING

EXCESSIVE OIL LEVEL AT TOP-UPS CAN LEAD TO SCALE FORMATION AND VEHICLE MALFUNCTION.

CAUTION

USED OILS CONTAIN SUBSTANCES HARMFUL TO THE ENVIRONMENT. FOR OIL REPLACEMENT, CONTACT AN AUTHORISED SERVICE CENTRE WHICH IS EQUIPPED TO DISPOSE OF USED OILS IN AN ENVIRONMENTALLY FRIENDLY AND LEGAL WAY.

CAUTION

USING OILS OTHER THAN THOSE RECOMMENDED CAN SHORTEN THE LIFE OF THE ENGINE.

Recommended products

eni i-Ride PG 5W-40

*Synthetic based lubricant for high-performance four-stroke engines.
JASO MA, MA2 - API SL - ACEA A3*

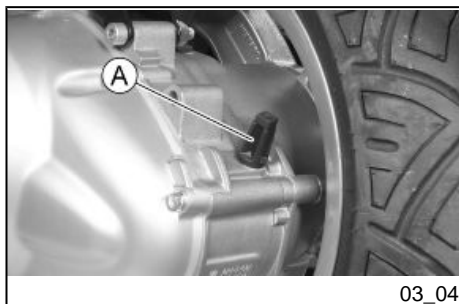

03_04

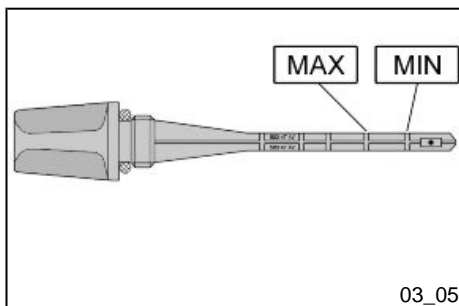

03_05

Hub oil level (03_04, 03_05)

Make sure there is oil in the rear hub checking this at the intervals specified in the scheduled maintenance table.

To check the rear hub oil level, proceed as follows:

1. Park the scooter on level ground and rest it on its centre stand.
2. Unscrew the oil dipstick «A», dry it with a clean cloth. Reinsert it and **screw it tightly into place**.
3. Pull out the dipstick and check that the oil level is between the **MIN** and **MAX** reference marks. If the oil level is below the **MIN** notch, top up with the required amount of hub oil.
4. Screw the dipstick back in, checking that it is locked in place.

N.B.

THE REFERENCE MARKS ON THE HUB OIL LEVEL DIPSTICK, EXCEPT FOR THE ONE INDICATING THE "MAX" LEVEL, REFER TO OTHER MODELS BY THE MANUFACTURER AND HAVE NO SPECIFIC FUNCTION FOR THIS MODEL.

CAUTION



RIDING THE VEHICLE WITH INSUFFICIENT HUB LUBRICATION OR WITH CONTAMINATED OR IMPROPER LUBRICANTS ACCELERATES THE WEAR AND TEAR OF THE MOVING PARTS AND CAN CAUSE SERIOUS DAMAGE.

CAUTION



USED OILS CONTAIN SUBSTANCES HARMFUL TO THE ENVIRONMENT. FOR OIL CHANGE, CONTACT AN AUTHORISED SERVICE CENTRE WHICH IS EQUIP-

PED TO DISPOSE OF USED OILS IN AN ENVIRONMENTALLY FRIENDLY AND LEGAL WAY.

Recommended products

AGIP GEAR SAE 80W-90

Lubricant for gearboxes and transmissions.

API GL-4

Characteristic

Transmission oil

100 cm³

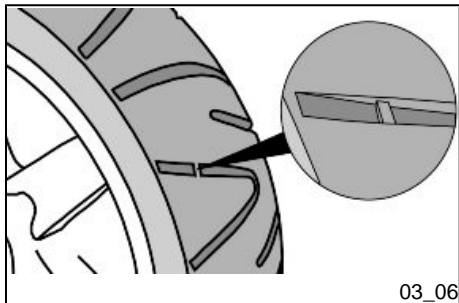

Tyres (03_06)

Periodically check the inflation pressure of each tyre (when cold).

Tyres are fitted with wear indicators; tyres should be replaced as soon as these indicators become visible on the tyre tread. Also check that the tyres do not show signs of splitting at the sides or irregular tread wear; If this occurs, go to an authorised workshop or at least a workshop adequately equipped to remove and refit tyres.

CAUTION



TYRE PRESSURE SHOULD BE CHECKED WHEN TYRES ARE COLD. INCORRECT TYRE PRESSURE CAUSES ABNORMAL TYRE WEAR AND MAKES RIDING DANGEROUS.

TYRES MUST BE REPLACED WHEN THE TREAD REACHES THE WEAR LIMITS SET FORTH BY LAW.

TYRES

Front tyre	Tubeless, 110/70 - 11" 45L
Rear tyre	Tubeless, 120/70 - 10" 54L

TYRE INFLATION PRESSURE

Front tyre pressure (with passenger)	1.6 bar (1.6 bar)
Rear tyre pressure (with passenger)	2.0 bar (2.3 bar)

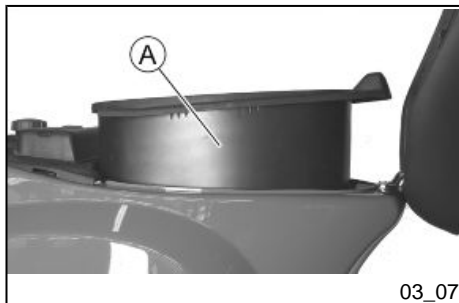

Spark plug dismantlement (03_07, 03_08, 03_09, 03_10)

In order to inspect the spark plug, follow the operation described when the engine is cold:

1. Lift the saddle and remove the helmet compartment «A».
2. Remove the spark plug inspection door «B».
3. Detach the spark plug cap.
4. Slide the door «C» on the engine cover upwards and off.
5. Remove the spark plug with the spanner «D» supplied (with retaining rubber ring).

To refit, repeat the procedure in reverse order using the spanner to insert the spark plug or to tighten it in its seat. Care should be taken to installing and fixing it with correct inclination

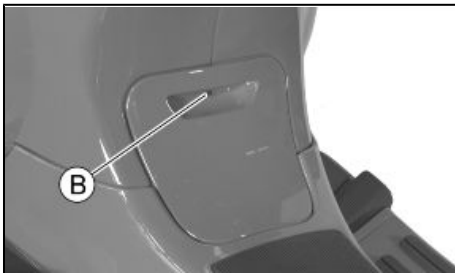

03_08



03_09

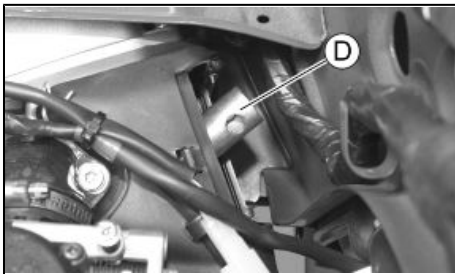

03_10

Be extremely careful when carrying out the operations described above, insert your left hand on the spark plug inspection door side and your right hand from the helmet compartment side.

To refit the door follow the steps in reverse order, making sure to insert the pin in the central cover.

CAUTION



THE SPARK PLUG MUST BE REMOVED WHEN THE ENGINE IS COLD. THE USE OF SPARK PLUGS OF DIFFERENT THERMAL GRADE FROM THAT REQUIRED OR WITH INAPPROPRIATE THREADS MAY SERIOUSLY DAMAGE THE ENGINE.

N.B.

USE OF SPARK PLUGS OTHER THAN THE INDICATED TYPE OR UNSHIELDED SPARK PLUG CAPS CAN LEAD TO FAULTS IN THE VEHICLE 'S ELECTRICAL SYSTEM.

Characteristic

Spark plug

CHAMPION RG 6 YC

Alternative spark plug

NGK CR7EB

Electrode gap

0.7 to 0.8 mm

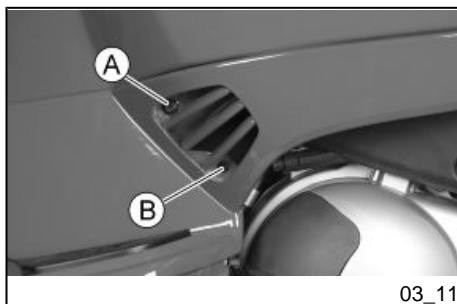

Removing the air filter (03_11, 03_12)

Remove the side fairing by undoing the screw «A» and the smaller screw «B». Take off air cleaner cover «D» after having unscrewed the 6 fixing screws «C», then take out the filter.

CAUTION



IN CASE OF RIDING ON DUSTY ROADS IT IS ADVISABLE TO CLEAN THE AIR FILTER MORE FREQUENTLY THAN INDICATED IN THE RELEVANT CHAPTER ON SCHEDULED MAINTENANCE.

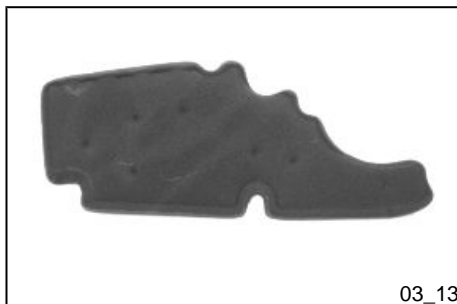
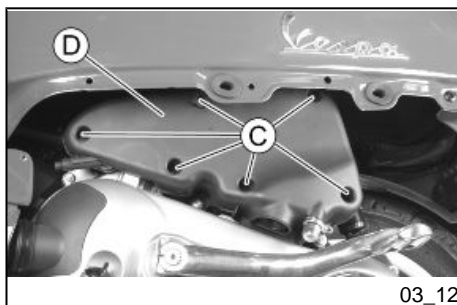

Air filter cleaning (03_13)

1. Wash the sponge with water and mild soap.
2. Dry it with a clean cloth and short blasts of compressed air.
3. Impregnate the sponge with a mixture of 50% petrol and 50% specified oil.
4. Gently squeeze the filtering element, let it drip dry and then refit it.

CAUTION

IF THE VEHICLE IS USED ON DUSTY ROADS IT IS NECESSARY TO CARRY OUT MAINTENANCE CHECKS OF THE AIR FILTER MORE OFTEN TO AVOID DAMAGING THE ENGINE.

Recommended products**AGIP FILTER OIL**

Special product for the treatment of foam filters.

-

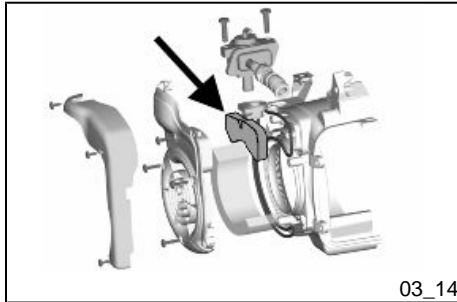

03_14

Secondary air system (03_14)

In order to reduce polluting emissions, the vehicle is furnished with a catalytic converter in the muffler.

To favour the catalytic process, an extra amount of oxygen is added via a secondary air system (SAS).

This system allows more oxygen to be added to the unburned gases before they reach the converter, thus improving the action of the catalytic converter.

The air enters the exhaust duct from the head, and is purified by a black filter.

The system is fitted with a control valve that disables operation while decelerating to avoid unwanted noise.

To ensure the best functioning of the SAS system, the scooter should be taken to an **Authorised Service Centre** to have the filter cleaned as indicated in the Scheduled Maintenance Table.

The filter sponge should be cleaned with water and mild soap, then it should be dried with a cloth and slight blows of compressed air.

WARNING

FOR THIS OPERATION, CONTACT AN AUTHORISED SERVICE CENTRE.

Checking the brake oil level (03_15)

The brake fluid reservoir is equipped with a sight glass «A» made of transparent material; the quantity of liquid contained in the sight glass indicates the level of liquid in the reservoir.

When the sight glass «A» is full, the level inside the reservoir exceeds the MIN level; when it is partially full, the level drops to the MIN level; when it is fully empty, the level of fluid in the reservoir is below the MIN level.

The brake fluid level may fall due to wear on the brake pads. In case the pad wear is below the minimum mark, contact an **Authorised Service Centre** to have the braking system thoroughly checked.

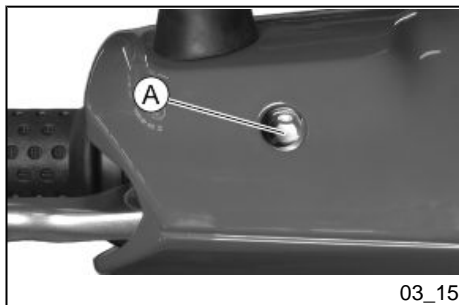

03_15

Braking system fluid top up (03_16, 03_17, 03_18)

Proceed as follows:

1. Remove the rear-view mirrors.
2. Undo the two screws «A».
3. Undo the screw «B» and remove the front handlebar cover.
4. Remove the reservoir cover «C» by loosening the two fixing screws «D» and refill with the prescribed brake fluid type only and without exceeding the maximum level.

Under standard climatic conditions, replace fluid as indicated in the scheduled maintenance table. This operation must be carried out by trained technicians; take your scooter to an **authorised Service Centre or Dealer**.

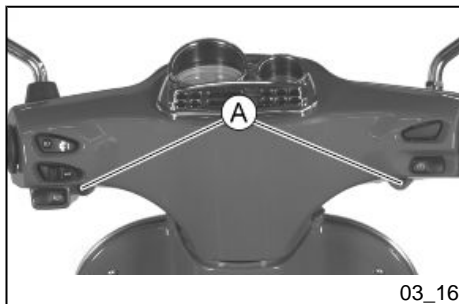

03_16

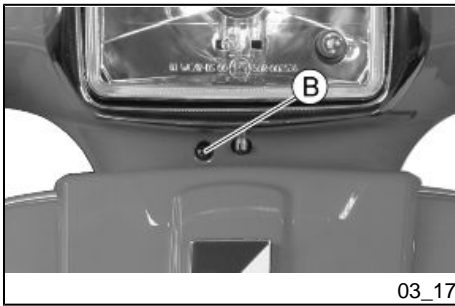

03_17

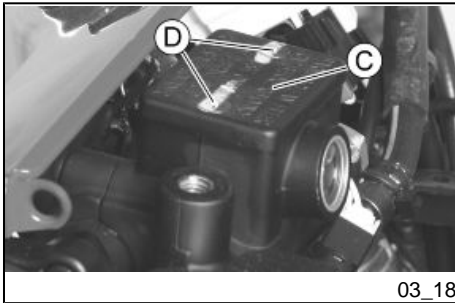

03_18

WARNING

ONLY USE DOT 4-CLASSIFIED BRAKE FLUID. BRAKE CIRCUIT FLUID IS VERY CORROSIVE; MAKE SURE THAT IT DOES NOT COME INTO CONTACT WITH THE PAINTWORK.

CAUTION

AVOID CONTACT OF BRAKE FLUID WITH EYES, SKIN, AND CLOTHING. IN CASE OF CONTACT, RINSE WITH WATER. THE BRAKING CIRCUIT FLUID IS HYGROSCOPIC, THAT IS, IT ABSORBS HUMIDITY FROM THE SURROUNDING AIR. IF THE HUMIDITY IN THE BRAKING FLUID EXCEEDS A CERTAIN VALUE, IT WILL LEAD TO INEFFICIENT BRAKING. NEVER USE BRAKING FLUID KEPT IN CONTAINERS THAT HAVE ALREADY BEEN OPENED, OR PARTIALLY USED.

Recommended products**AGIP BRAKE 4**

Brake fluid.

Synthetic fluid SAE J 1703 - FMVSS 116 - DOT 3/4 - ISO 4925 - CUNA NC 956 DOT 4

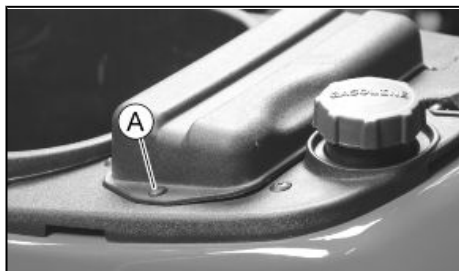

03_19

Battery (03_19)

To access the battery it is necessary to tilt the saddle forwards, then remove the battery compartment access cover by undoing the screw «A».

The battery is the electrical device that requires the most frequent attention and the most thorough maintenance.

WARNING



USED BATTERIES ARE HARMFUL FOR THE ENVIRONMENT. COLLECTION AND DISPOSAL SHOULD BE CARRIED OUT IN COMPLIANCE WITH REGULATIONS IN FORCE.

WARNING



IN ORDER TO AVOID DAMAGING THE ELECTRICAL SYSTEM, NEVER DISCONNECT THE WIRING WHILE THE ENGINE IS RUNNING.

Use of a new battery (03_20)

To install a new battery:

1. Place the battery in its housing.
2. Connect the positive pole «+» first and then the negative pole «-».
3. Place the battery cover.

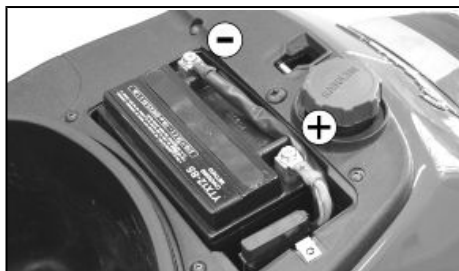

03_20

CAUTION

DO NOT REVERSE THE POLARITY: RISK OF SHORT CIRCUIT AND DAMAGE TO THE ELECTRICAL SYSTEM.

WARNING

USED BATTERIES ARE HARMFUL FOR THE ENVIRONMENT. COLLECTION AND DISPOSAL SHOULD BE CARRIED OUT IN COMPLIANCE WITH REGULATIONS IN FORCE.

Characteristic**Battery**

Sealed, 12 V / 10 Ah

Long periods of inactivity

Battery performance will be poor if the vehicle is not used for a long time. This is the result of the natural phenomenon of battery discharging, and may be due to residual absorption by vehicle components with constant power consumption. Poor battery performance may also be due to environmental conditions and the cleanliness of the poles. In order to avoid difficult starts and/or irreversible damage to the battery, follow any of these steps:

- **At least once a month** start the engine and run it slightly above idle speed for 10-15 minutes. This keeps all the engine components, as well as the battery, in good working order.
- Take your vehicle to a garage (as indicated in the «Vehicle not used for extended periods» section) to have the battery removed. Have the battery cleaned, charged

fully and stored in a dry, ventilated place. Recharge **at least once every two months**.

CAUTION

THE BATTERY MUST BE CHARGED WITH A CURRENT EQUAL TO 1/10 OF THE RATED CAPACITY OF THE BATTERY AND FOR NOT LONGER THAN 10 HOURS. CONTACT AN AUTHORISED SERVICE CENTRE TO CARRY OUT THIS OPERATION SAFELY. WHEN REFITTING THE BATTERY MAKE SURE THE LEADS ARE CORRECTLY CONNECTED TO THE TERMINALS.

WARNING

DO NOT DISCONNECT THE BATTERY CABLES WITH THE ENGINE RUNNING, THIS CAN CAUSE IRREPARABLE DAMAGE TO THE VEHICLE'S ELECTRONIC CONTROL UNIT.

WARNING

USED BATTERIES ARE HARMFUL FOR THE ENVIRONMENT. COLLECTION AND DISPOSAL SHOULD BE CARRIED OUT IN COMPLIANCE WITH REGULATIONS IN FORCE.

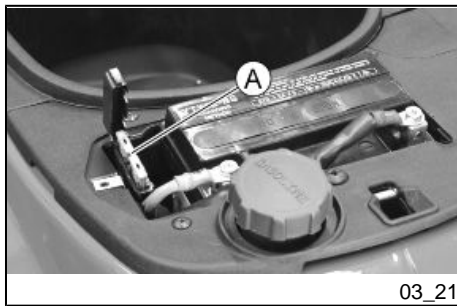

03_21

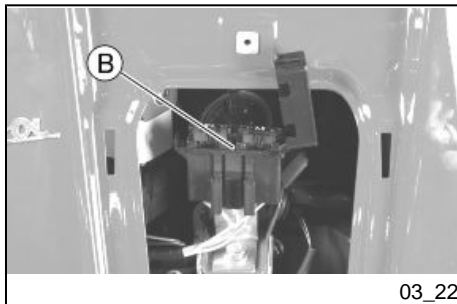

03_22

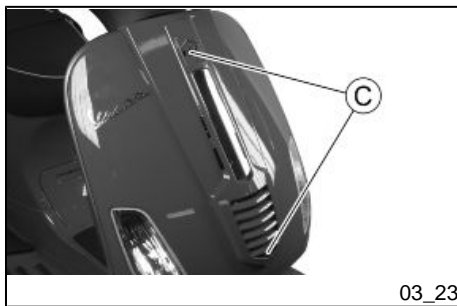

03_23

Fuses (03_21, 03_22, 03_23, 03_24)

The vehicle electrical system is protected by four fuses.

Two 15A fuses «A» located next to the battery. Remove the battery cover located under the saddle to reach them.

Two 7.5A fuses «B» located under the front grille. Remove the Piaggio clip-on badge, undo screws «C» and remove the front grille to reach them.

CAUTION



IN ORDER TO AVOID DAMAGING THE ELECTRICAL SYSTEM, NEVER DISCONNECT THE WIRING WHILE THE ENGINE IS RUNNING. DO NOT TIP THE VEHICLE TOO MUCH IN ORDER TO AVOID DANGEROUS LEAKAGE OF THE BATTERY ELECTROLYTE.

CAUTION



MODIFICATIONS OR REPAIRS TO THE ELECTRICAL SYSTEM, PERFORMED INCORRECTLY OR WITHOUT STRICT ATTENTION TO THE TECHNICAL SPECIFICATIONS OF THE SYSTEM CAN CAUSE MALFUNCTIONING AND RISK OF FIRE.

CAUTION



BEFORE REPLACING A BLOWN FUSE, FIND AND SOLVE THE FAILURE THAT CAUSED IT TO BLOW. NEVER TRY TO REPLACE THE FUSE WITH ANY OTHER MATERIAL (E.G., A PIECE OF ELECTRIC WIRE).

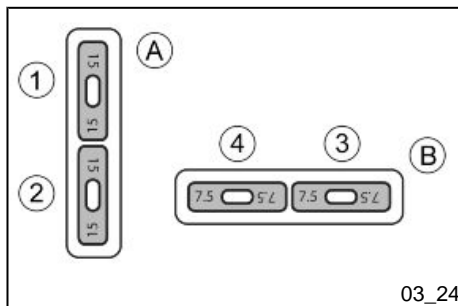

FUSES

Fuse No. 1

Capacity: 15A

Protected circuits: Battery-powered control unit, recharge circuit. Live power supply to carburettor heater, automatic starter, control unit, air valve, electric pump control device, circuits protected by fuses No. 3-4.

Location: battery compartment .

Fuse No. 2

Capacity: 15 A

Protected circuits: Battery-powered high-beam lights and low-beam lights (via relay).

Location: battery compartment.

Fuse No. 3

Capacity: 7.5 A

Protected circuits:Permanent power supply to transmitter/fuel gauge, stop lights, starter circuit, engine oil pressure sensor/warning light, horn, headlight relay.

Location: front grille.

Fuse No. 4

Capacity: 7.5 A

Protected circuits:Permanent power supply to tail lights, license plate light, panel lighting.

Location: front grille.

Lamps

BULBS

High/low beam light bulb

Type: Halogen (H4)

Power: 12V - 55/60W

Quantity: 1

Front side light bulb

Type: Incandescent (W2.1x9.5d)

Power: 12V - 5W

Quantity: 1

Front turn indicator light bulb

Type: Incandescent (BA 15s)

	Power: 12V - 10W Quantity: 1 RHS + 1 LHS
Rear turn indicator light bulb	Type: Incandescent (BA 15s) Power: 12V - 10W Quantity: 1 RHS + 1 LHS
Stop and tail light bulb	Type: Incandescent (BAY 15s) Power: 12V - 21/5W Quantity: 1
turn indicators warning lights, low-beam lights, high-beam lights, low fuel, low oil	Type: Incandescent Power: 12V - 1.2W Quantity: 5
Instrument panel bulb	Type: Incandescent Power: 12V - 2W Quantity: 3
License plate bulb	Type: Incandescent (W2.1 x 9.5D) Power: 12V - 5W Quantity: 1

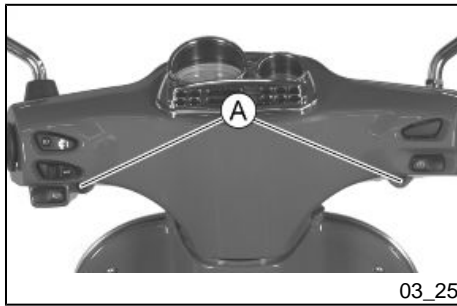

03_25

Front light group (03_25, 03_26, 03_27, 03_28)

To access the headlight bulbs, remove the front of the handlebar cover, as follows:

1. Remove the rear-view mirrors.
2. Unscrew the 3 screws holding the handlebar cover. The front central screw «B» and the 2 rear screws «A». Once this is done, the handlebar cover can be removed.

To replace the high-/low-beam headlight bulb:

1. Disconnect the power contacts and remove the rubber protection «C».
2. Remove the retaining clip «D» and slide off the bulb.

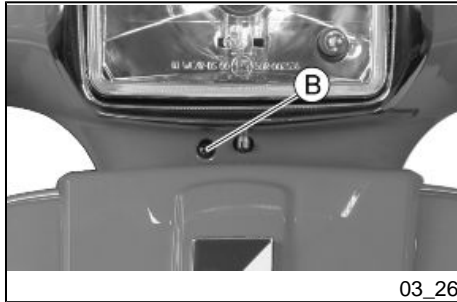

03_26

To replace the tail light bulb:

1. Slide off the rubber bulb holder «E» from its fitting.
2. Hold and slide off the bulb.

N.B.

IF MISTING IS NOTICED ON THE INSIDE OF THE HEADLAMP GLASS, THIS DOES NOT INDICATE A FAULT AND IS ATTRIBUTABLE TO HUMIDITY AND/OR TO LOW TEMPERATURES.

THE PHENOMENON SHOULD QUICKLY DISAPPEAR WHEN THE LIGHT IS SWITCHED ON.

THE PRESENCE OF DROPS OF WATER, ON THE OTHER HAND, COULD INDICATE THAT WATER IS INFILTRATING. CONTACT THE AFTER-SALES SERVICE NETWORK.

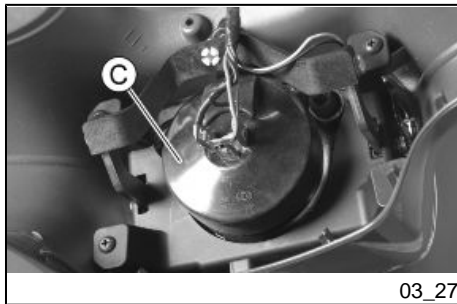

03_27

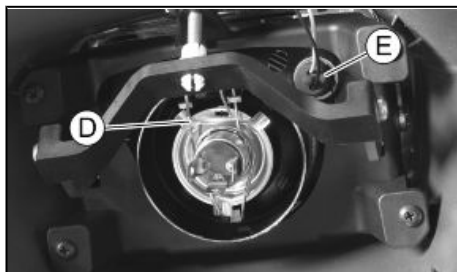

03_28

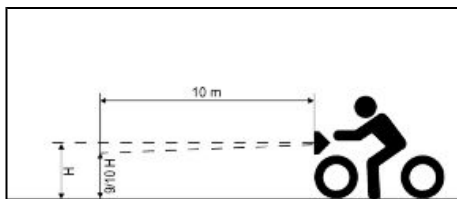

03_29



03_30

Head light adjustment (03_29, 03_30)

Proceed as follows:

1. Place the vehicle in running order and with the tyres inflated to the prescribed pressure, on a flat surface 10 m away from a white screen situated in a shaded area, making sure that the longitudinal axis of the vehicle is perpendicular to the screen;
2. Turn on the headlight and check that the borderline of the projected light beam on the screen is no higher than 9/10 or lower than 7/10 of the distance from the ground to the centre of the vehicle's headlamp;
3. If otherwise, adjust the right headlight with screw «A».

N.B.

THE ABOVE PROCEDURE COMPLIES WITH THE EUROPEAN STANDARDS REGARDING MAXIMUM AND MINIMUM HEIGHT OF LIGHT BEAMS. REFER TO THE STATUTORY REGULATIONS IN FORCE IN EVERY COUNTRY WHERE THE VEHICLE IS USED.

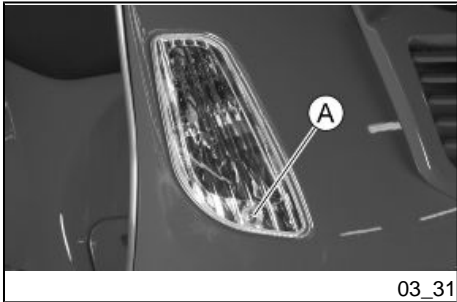

Front direction indicators (03_31, 03_32)

To replace the bulbs:

1. Remove the turn indicator from its fitting by undoing the screw «A».
2. Take out the bulb holder «B» from its fitting by turning it anticlockwise.
3. Press the bulb, turn it anticlockwise and then take it out.

To refit, proceed in reverse order.

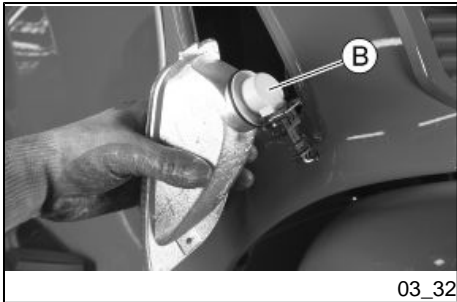

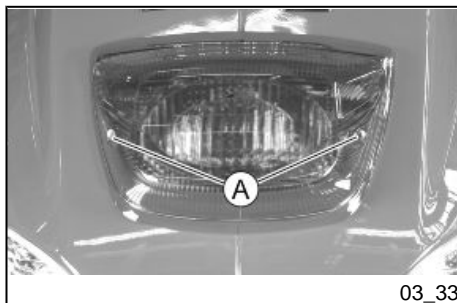

03_33

Rear optical unit (03_33, 03_34)

To replace the taillight bulb:

1. Remove the two screws «A».
2. Take out the bulb holder «B» from its fitting by turning it anticlockwise.
3. Press the bulb, turn it anticlockwise and then take it out.

To refit, proceed in reverse order.

N.B.

IF MISTING IS NOTICED ON THE INSIDE OF THE HEADLAMP GLASS, THIS DOES NOT INDICATE A FAULT AND IS ATTRIBUTABLE TO HUMIDITY AND/OR TO LOW TEMPERATURES.

THE PHENOMENON SHOULD QUICKLY DISAPPEAR WHEN THE LIGHT IS SWITCHED ON.

THE PRESENCE OF DROPS OF WATER, ON THE OTHER HAND, COULD INDICATE THAT WATER IS INFILTRATING. CONTACT THE AFTER-SALES SERVICE NETWORK.

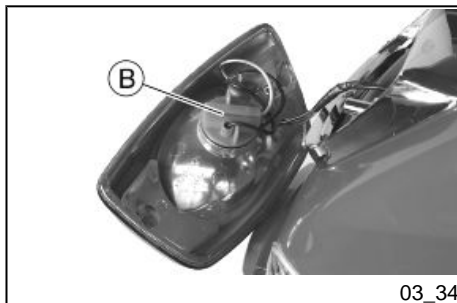

03_34

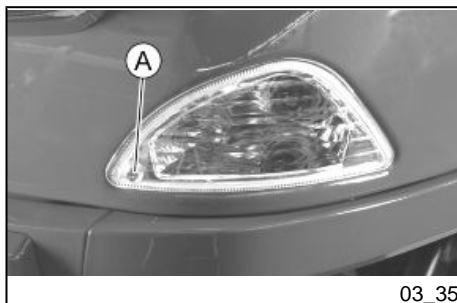

03_35

Rear turn indicators (03_35, 03_36)

To replace the bulbs:

1. Remove the turn indicator from its fitting by undoing the screw «A».
2. Take out the bulb holder «B» from its fitting by turning it anticlockwise.
3. Press the bulb, turn it anticlockwise and then take it out.

To refit, proceed in reverse order.

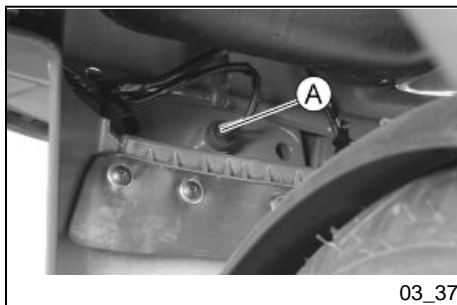
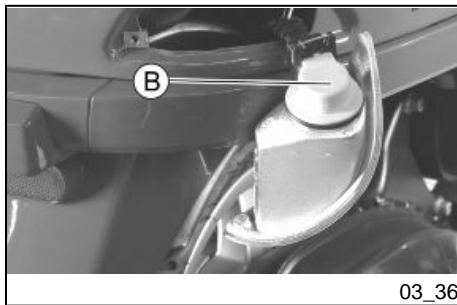

Number plate light (03_37)

To replace the bulb:

1. Hold the rubber bulb holder «A» and take it out.
2. Slide off the bulb from the bulb holder and replace it.

Rear-view mirrors (03_38)

The mirrors can be set to the desired position by adjusting the mirror frame.

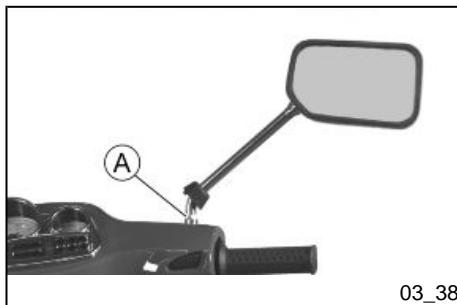

03_38

To remove the rear view mirror unscrew the nut «A» and turn the rear-view mirror supporting stem anticlockwise.

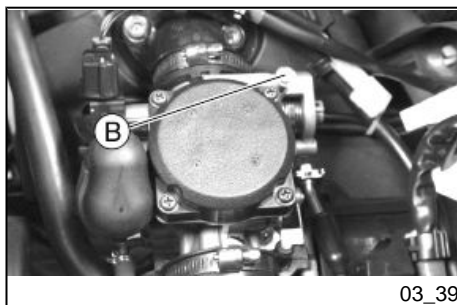

03_39

Idle adjustment (03_39)

Proceed as follows:

1. Rest the scooter on its centre stand and lift the saddle.
2. Remove the helmet compartment.
3. To adjust the idle speed, start the engine, then loose or tighten the screw «B» until you reach the recommended idle speed taking care the engine does not make the rear wheel move.

If it is difficult to adjust idle speed, take your vehicle to an **Authorised Service Centre or Dealer**.

WARNING



IDLE SPEED MUST BE ADJUSTED WHEN THE ENGINE IS VERY HOT. BEFORE THIS OPERATION, MAKE SURE THAT THE THROTTLE GRIP HAS THE RECOMMENDED BACKLASH. IF BACKLASH IN THE THROTTLE CONTROL TRANSMISSION NEEDS ADJUSTING TAKE YOUR SCOOTER TO AN AUTHORISED DEALER OR SERVICE CENTRE



Characteristic

Engine idle speed

1,650±100 rpm

Front disc brake (03_40)

The brake disc and pad wear is automatically compensated, therefore it has no effect on the functioning of the front and rear brakes. For this reason it is not necessary to adjust the brakes. An excessively elastic brake lever stroke may indicate the presence of air in the braking circuit or a failure in the braking system. In this case, mainly due to the importance of brakes to guarantee safe riding conditions, the vehicle should be taken to an **Authorised Service Centre or Dealer**.

CAUTION



BRAKING SHOULD BEGIN AFTER ABOUT 1/3 OF THE BRAKE LEVER STROKE.

CAUTION



HAVE THE BRAKE PADS CHECKED BY THE DEALER ACCORDING TO THE CHECKS SPECIFIED IN THE SCHEDULED MAINTENANCE TABLE. HOWEVER, IN THE EVENT OF NOISES COMING FROM THE FRONT AND/OR REAR BRAKING SYSTEM DURING OPERATION, IT IS ADVISABLE TO HAVE THE BRAKING SYSTEM CHECKED BY AN AUTHORISED SERVICE CENTRE OR DEALER. AFTER REPLACING THE BRAKE PADS, DO NOT USE THE SCOOTER UNTIL YOU HAVE OPERATED THE BRAKE LEVER SEVERAL TIMES IN ORDER TO ALLOW THE PLUNGERS TO SETTLE AND THE LEVER STROKE TO BE SET TO THE CORRECT POSITION.

CAUTION

THE PRESENCE OF SAND, MUD, SNOW MIXED WITH SALT, ETC. ON THE ROAD, CAN DRASTICALLY REDUCE THE LIFE OF THE BRAKE PADS. IN ORDER TO AVOID THIS, WE RECOMMEND WASHING THE VEHICLE FREQUENTLY WHEN RIDING IN THESE ROAD CONDITIONS.

Rear drum brake (03_41)

Operate adjusting nut «B» and loosen lock nut «A» shown in the figure. Note that when the throttle is in idle **the wheel should rotate free**. After the adjustment, screw lock nut «A».

CAUTION

BRAKING SHOULD BEGIN AFTER ABOUT 1/3 OF THE BRAKE LEVER STROKE.

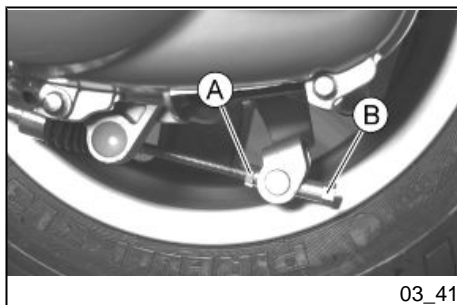

03_41

Puncture

The vehicle is equipped with Tubeless tyres (without inner tube). In the event of a puncture, Tubeless tyres - unlike tyres with inner tubes - go flat very slowly, resulting in a greater steering safety. In the event of a puncture, an emergency repair can be carried out using an "inflate and repair" spray can. For a final repair, take your vehicle to an **Authorised Service Centre or Dealer**. The replacement of a tyre involves removing the wheel in question. Take your vehicle to an **Authorised Service Centre or Dealer** for these operations.

CAUTION

TO USE THE "INFLATE AND REPAIR" SPRAY CAN PROPERLY, FOLLOW THE INSTRUCTIONS ON THE PACKAGING.

WARNING

THE WHEELS FITTED WITH TYRES SHOULD ALWAYS BE BALANCED. RIDING THE VEHICLE WITH VERY LOW TYRE PRESSURE OR WITH INCORRECTLY BALANCED TYRES CAN LEAD TO DANGEROUS STEERING VIBRATIONS.



03_42

Inactivity of the vehicle (03_42)

We recommend carrying out the following operations:

1. General cleaning of the vehicle.
2. With the engine off and the piston at bottom dead centre position, remove the spark plug and pour 1÷2 cm³ of motor oil through its fill opening. Operate the starter 3-4 times letting the engine perform a few revolutions, then remount the spark plug.
3. Bleed all the vehicle's fuel; spread antirust grease on the unpainted metal parts; keep the wheels lifted above the ground.
4. For the battery, follow the procedures described in the «Battery» section.
5. Drain the petrol off the carburettor float chamber.
6. Replace the engine oil.

Recommended products**eni i-Ride PG 5W-40**

Synthetic based lubricant for high-performance four-stroke engines.

Cleaning the vehicle

Use a low pressure jet of water to soften the caked dirt and mud deposited on the painted surfaces. Once softened, sponge off mud and dirt using a car body sponge soaked in a car body shampoo and water solution (2-4% of car shampoo in water). Then rinse with abundant water, and dry with a shammy cloth. For the engine exterior, use petrol, a brush and clean cloths. Petrol can damage paintwork. Remember that any polishing with silicone wax must always be preceded by washing.

CAUTION



DETERGENTS POLLUTE WATER. THEREFORE THE VEHICLE SHOULD BE WASHED IN AN AREA EQUIPPED FOR THE COLLECTION AND PURIFICATION OF THE LIQUIDS USED.

WARNING



NEVER WASH THE VEHICLE UNDER DIRECT SUNLIGHT, ESPECIALLY IN SUMMER WHEN THE BODYWORK IS STILL HOT, AS THE CAR SHAMPOO MAY DRY BEFORE BEING RINSED OFF, AND COULD DAMAGE THE PAINTWORK. NEVER USE RAGS SOAKED IN PETROL OR DIESEL OIL TO CLEAN THE PAINTED OR PLASTIC SURFACES, IN ORDER TO PREVENT THEM LOSING THEIR SHINE AND MECHANICAL CHARACTERISTICS.

WARNING

WHEN WASHING THE ENGINE WITH A HIGH-PRESSURE WATER JET:

- **ONLY USE FAN SPRAY JETS.**
- **DO NOT PLACE THE NOZZLE CLOSER THAN 60 CM.**
- **DO NOT USE WATER AT TEMPERATURES OVER 40° C.**
- **DO NOT DIRECT THE JETS DIRECTLY TO CARBURETTOR, WIRINGS, SLOT DIFFUSERS ON THE TRANSMISSION COVER AND SCROLL COVER.**

WARNING

CLEAN YOUR SCOOTER FREQUENTLY SO AS TO AVOID POSSIBLE DIRT OR MUD DEPOSITS THAT COULD CAUSE MALFUNCTIONING IN THE THROTTLE GRIP TRANSMISSION AND/OR OTHER COMPONENTS.

CLEANING CHROME-PLATED PARTS

After cleaning chrome-plated parts, polish them with a specific product for chrome-plated, aluminium or stainless steel surfaces. To prevent corrosion, apply a protective spray on all the metal surfaces, including chrome- and nickel-plated ones. Apply spray oil and wax with moderation and make sure to wipe off excess product immediately.

CAUTION

NEVER APPLY OIL AND WAX ON RUBBER AND PLASTIC PARTS.

CAUTION

CHECK THAT THERE IS NO OIL OR WAX ON THE TYRES. BEFORE USING YOUR SCOOTER TEST ITS BRAKING EFFICIENCY AND BEHAVIOUR ON A BEND.

Troubleshooting**START-UP PROBLEMS**

No fuel in tank	Refuel
Filters, jets or carburettor body dirty or clogged.	Contact an Authorised Service Centre .
Insufficient battery charge	Recharge the battery.

IGNITION PROBLEMS

No spark from spark plug. Due to the presence of high voltage, this check should only be carried out by an expert.	Check that the electrodes are properly adjusted. Check that the electrodes are clean (use pure petrol and a metal brush or emery cloth). Check the spark plug insulator: Replace the spark plug if the insulator is cracked or broken. If the spark plug is in good
--	---

conditions, contact an **Authorised Service Centre**.

LACK OF COMPRESSION

Spark plug adapter "worn", valve clearance not adequate; worn piston gas rings	Contact an Authorised Service Centre .
--	---

HIGH CONSUMPTION AND LOW PERFORMANCE

Air filter blocked or dirty.	Clean with water and shampoo and impregnate with petrol and specific oil («Air filter removal» section)
------------------------------	---

INEFFICIENT BRAKING

Oil on drum or disc. Worn Pads/ Shoes	Contact an Authorised Service Centre
incorrect rear brake adjustment	Adjust

INEFFICIENT SUSPENSION

Inefficient shock absorbers, oil leakage, deteriorated end of stroke buffers.	Contact an Authorised Service Centre
---	---

AUTOMATIC TRANSMISSION PROBLEMS

Deteriorated CVT rollers and/or drive belt and/or clutch	Contact an Authorised Service Centre
--	---

EXHAUST NOISE

Depression tube damaged/disconnected or secondary valve damaged	Contact an Authorised Service Centre
---	---

STAND DOES NOT RETURN TO POSITION

Presence of dirt	Clean and grease
------------------	------------------

Vespa S 150

Vespa®



Chap. 04
Technical data

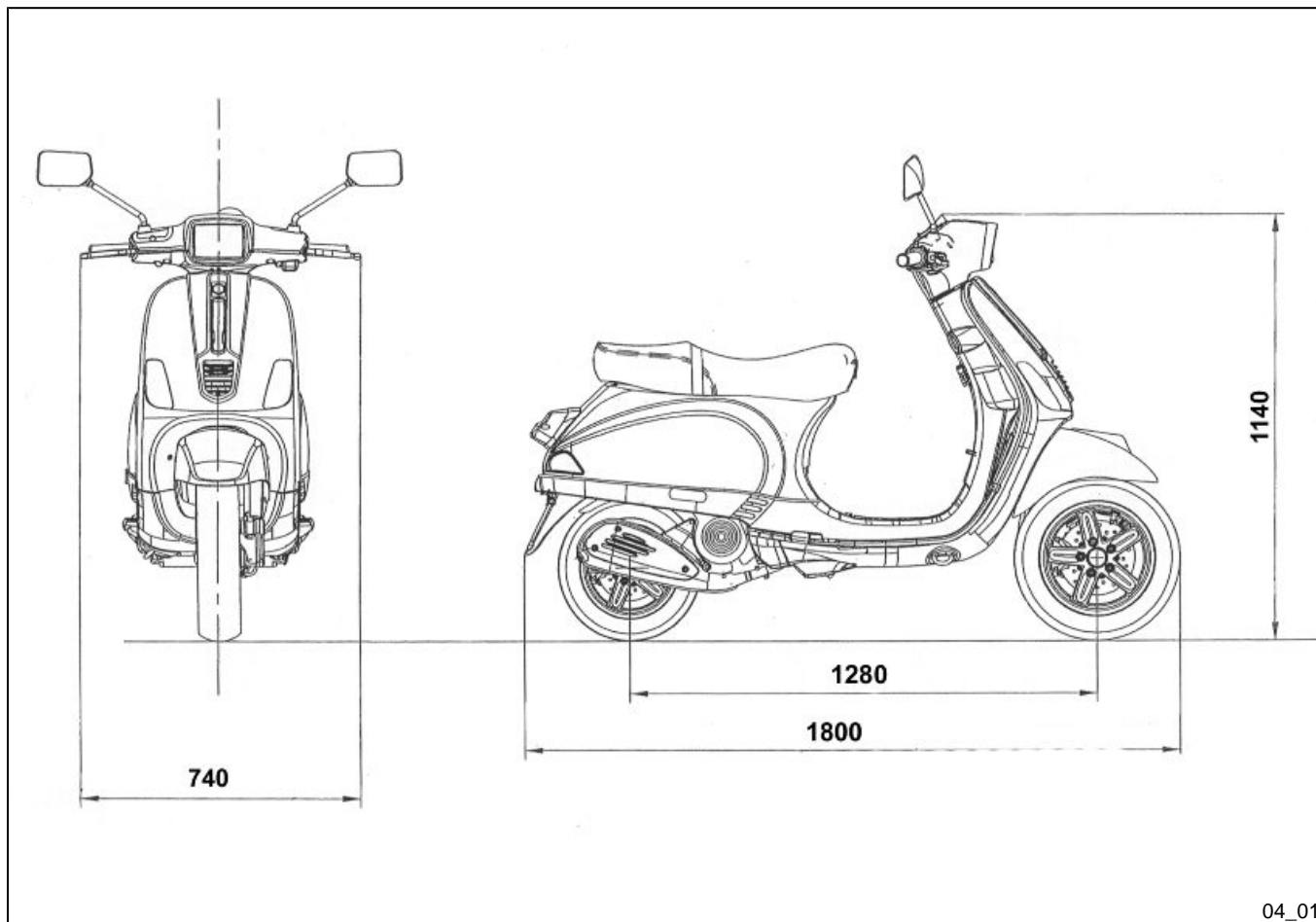

ENGINE TECHNICAL DATA

Type	Single-cylinder, 4-stroke
Cubic capacity	124 cm ³
Bore x stroke	57.0 x 48.6 mm
Compression ratio	10.6 ± 0.5: 1
Engine idle speed	1650 ± 100 rpm
Timing system	2 valves, single overhead camshaft, chain-driven.
Valve clearance (cold engine)	Intake: 0.10 mm Exhaust: 0.15 mm
Max. power	8.9 kW at 7,750 rpm
MAX. torque	11.8 Nm at 6,500 rpm
Transmission	CVT expandable pulley variator with torque server, V-belt, self-ventilating dry automatic centrifugal clutch and transmission housing with forced-circulation air cooling.
Final reduction gear	Gear reduction unit in oil bath.
Lubrication	Engine lubrication with lobe pump (inside crankcase), chain-driven, with double filter: mesh and paper.
Cooling	Forced-air circulation cooling.
Starter	Electrical and kick starter (where fitted)

Ignition	Capacitive discharge ignition, with variable advance and separate HV coil.
Ignition advance	Three-dimensional map managed by control unit
Spark plug	CHAMPION RG 6 YC
Alternative spark plug	NGK CR7EB
Fuel supply	KEIHIN CVK 26 Carburettor and electrical fuel pump.
Fuel	Unleaded petrol (95 RON)
Exhaust silencer	Absorption-type exhaust muffler with catalytic converter.
Emissions compliance	EURO 3

VEHICLE TECHNICAL DATA

Chassis	Stamped plate body with welded structural reinforcements.
Front suspension	Single arm with helical spring and single double-acting hydraulic shock absorber.
Rear suspension	Double-acting shock absorber, adjustable to four positions at preloading.
Front brake	Ø 200-mm disc brake with hydraulic control activated by handlebar right-side lever.

Rear brake	Ø 110-mm drum brake with mechanical control activated by handlebar left-side lever.
Wheel rim type	Light alloy wheel rims.
Front wheel rim	11" x 2.50
Rear wheel rim	10" x 3.00
Front tyre	Tubeless, 110/70 - 11" 45L
Rear tyre	Tubeless, 120/70 - 10" 54L
Front tyre pressure (with passenger)	1.6 bar (1.6 bar)
Rear tyre pressure (with passenger)	2.0 bar (2.3 bar)
Kerb weight	114 ± 5 kg
Maximum weight allowed	300 kg
Battery	Sealed, 12 V / 10 Ah

CAPACITY

Engine oil	1.10 l
Transmission oil	100 cm ³
Cooling system fluid	-
Fuel tank (reserve)	~ 8.5 l (2 l)

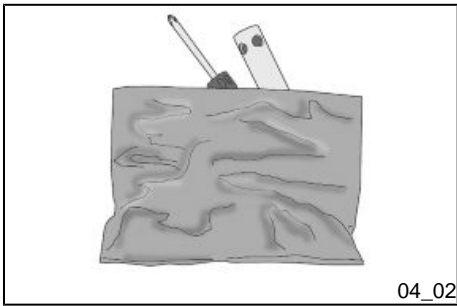

Toolkit (04_02)

The toolkit comprises:

- One box-spanner.
- One twin screwdriver.
- One special spanner for adjusting rear shock absorbers.

The tools are stored in the helmet compartment.

Vespa S 150

Vespa®



Chap. 05
Spare parts and
accessories



Warnings (05_01)

WARNING



IT IS RECOMMENDED THAT "ORIGINAL PIAGGIO SPARE PARTS" BE USED, AS THESE ARE THE ONLY ONES OFFERING YOU THE SAME QUALITY ASSURANCE AS THOSE INITIALLY FITTED ON THE VEHICLE.

IT SHOULD BE REMEMBERED THAT USING NON-ORIGINAL SPARE PARTS CAUSES YOUR WARRANTY RIGHTS TO EXPIRE.

WARNING



PIAGGIO MARKETS ITS OWN LINE OF ACCESSORIES THAT ARE RECOGNISED AND GUARANTEED FOR USE. IT IS THEREFORE ESSENTIAL TO CONTACT AN AUTHORISED DEALER OR SERVICE CENTRE IN ORDER TO CHOOSE AND FIT ACCESSORIES CORRECTLY. THE USE OF NON-ORIGINAL ACCESSORIES MAY AFFECT THE STABILITY AND OPERATION OF YOUR VEHICLE AND REDUCE SAFETY LEVELS WITH POTENTIAL RISKS FOR THE RIDER.

Vespa S 150

Vespa®



**Chap. 06
Scheduled
maintenance**



Scheduled servicing table (06_01)

Adequate maintenance is fundamental to ensuring long-lasting, optimum operation and performance of your vehicle.

To this end, a series of checks and maintenance operations (at the owner's expense) have been suggested, which are included in the summary table on the following page. Any minor faults should be reported without delay to an **Authorised Service Centre or Dealer** without waiting until the next scheduled service to solve it.

It is indispensable to have your vehicle serviced to the prescribed intervals of time, even if you have not reached the predicted mileage. Punctual vehicle servicing is necessary for the correct use of the guarantee. For any further information concerning Warranty procedures and 'Scheduled Maintenance', please refer to the 'Warranty Booklet'.

MAINTENANCE TABLE

Km x 1,000	1	6	12	18	24	30	36	42	48	54	60
Safety fasteners	I		I		I		I		I		I
Spark plug		I	R	I	R	I	R	I	R	I	R
Centre stand bracket		L	L	L	L	L	L	L	L	L	L
Drive belt		I	R	I	R	I	R	I	R	I	R
Throttle control	A		A		A		A		A		A
Air filter		C	C	C	C	C	C	C	C	C	C
SAS filter			C		C		C		C		C
Oil filter		R	R	R	R	R	R	R	R	R	R
Mesh oil filter	C	C	C	C	C	C	C	C	C	C	C
Valve clearance		A		A			A			A	

Km x 1,000	1	6	12	18	24	30	36	42	48	54	60
Electrical system and battery	I	I	I	I	I	I	I	I	I	I	I
Cylinder ventilation system					C				C		
Brake levers	L		L		L		L		L		L
Brake fluid **	I	I	I	I	I	I	I	I	I	I	I
Engine oil *	R	R	R	R	R	R	R	R	R	R	R
Hub oil	R	I	I	I	R	I	R	I	R	I	I
Headlight direction adjustment			A		A		A		A		A
Brake pads	I	I	I	I	I	I	I	I	I	I	I
Sliding shoes / CVT rollers		I	R	I	R	I	R	I	R	I	R
Tyre pressure and wear	I	I	I	I	I	I	I	I	I	I	I
Vehicle road test	I	I	I	I	I	I	I	I	I	I	I
Idle speed	A		A		A		A		A		A
Odometer gear			L		L		L		L		L
Suspension			I		I		I		I		I
Steering	A		A		A		A		A		A
Transmission			L		L		L		L		L

I: INSPECT AND CLEAN, ADJUST, LUBRICATE OR REPLACE IF NECESSARY

C: CLEAN, R: REPLACE, A: ADJUST, L: LUBRICATE

Clean the SAS air filter every 2 years

** Check level every 3,000 km*

*** Replace every 2 years*

RECOMMENDED PRODUCTS TABLE

Product	Description	Specifications
AGIP GEAR SAE 80W-90	Lubricant for gearboxes and transmissions.	API GL-4
AGIP BRAKE 4	Brake fluid.	Synthetic fluid SAE J 1703 - FMVSS 116 - DOT 3/4 - ISO 4925 - CUNA NC 956 DOT 4
eni i-Ride PG 5W-40	Synthetic based lubricant for high-performance four-stroke engines.	JASO MA, MA2 - API SL - ACEA A3
AGIP FILTER OIL	Special product for the treatment of foam filters.	-
AGIP GREASE MU3	Yellow-brown, lithium-base, medium-fibre multipurpose grease.	ISO L-X-BCHA 3 - DIN 51 825 K3K -20
AGIP GP 330	Water repellent stringy calcium spray grease.	R.I.D./A.D.R. 2 10°b) 2 R.I.Na. 2.42 - I.A.T.A. 2 - I.M.D.G. class 2 UN 1950 Page 9022 EM 25-89

UNIT OF MEASURE - CONVERSION - ENGLISH SYSTEM TO INTERNATIONAL SYSTEM (IS).

1 Inch (in)	25.4 Millimetres (mm)
1 Foot (ft)	0.305 Meter (m)
1 Mile (mi)	1.609 Kilometre (km)
1 US Gallon (USgal)	3.785 Litre (l)
1 Pound (lb)	0.454 Kilogram (kg)
1 Cubic inch (in ³)	16.4 Cubic centimetres (cm ³)
1 Foot pound (lb ft)	1,356 Newton meter (Nm)

1 Miles per hour (mi/h)	1.602 Kilometres per hour (km/h)
1 Pound per square inch (PSI)	0.069 (bar)
1 Fahrenheit (°F)	$32+(9/5)$ Celsius (°C)

6 Scheduled maintenance

TABLE OF CONTENTS

A

Air filter: 41

B

Battery: 45

Brake: 43, 58, 59

C

Checks: 20

Clock: 11

D

Disc brake: 58

E

Engine oil: 34, 35

F

Fuel: 15

Fuses: 48

H

Horn: 14

Hub oil: 37

I

Identification: 16

Instrument panel: 11

K

Keys: 16

L

Light switch: 14

M

Maintenance: 33, 75

Mirrors: 56

P

Puncture: 59

R

Refuelling: 20

S

Saddle: 16

Scheduled maintenance: 75

Shock absorbers: 22

Spark plug: 39

Stand: 28

Start-up: 15

Switch: 13, 14

T

Tank: 15

Technical Data: 67

Transmission: 29

Turn indicators: 55

Tyre pressure: 21

Tyres: 38

V

Vehicle: 7, 60, 61



The descriptions and illustrations given in this publication are not binding. While the basic specifications as described and illustrated in this manual remain unchanged, PIAGGIO-GILERA reserves the right, at any time and without being required to update this publication beforehand, to make any changes to components, parts or accessories, which it considers necessary to improve the product or which are required for manufacturing or construction reasons.

Not all versions/models shown in this publication are available in all countries. The availability of single versions should be checked at the official Piaggio sales network.

"© Copyright 2008 - PIAGGIO & C. S.p.A. Pontedera. All rights reserved. Reproduction of this publication in whole or in part is prohibited."

PIAGGIO & C. S.p.A. - After-Sales

V.le Rinaldo Piaggio, 23 - 56025 PONTEDERA (Pi)